

MAINTENANCE AND OPERATION
INSTRUCTION MANUAL

DB90-TX

IP Audio Encoder



Contents

Introduction	5
Typographic conventions	6
General Information	7
<i>Application</i>	7
<i>Product Features</i>	8
<i>Technical Specifications</i>	9
<i>Block Diagram</i>	10
Safety Warning	11
Unpacking and inspection	12
Mounting	12
<i>Rack Requirements IU</i>	12
<i>Rack Requirements Compact Units</i>	12
<i>Stand-Alone Devices</i>	12
Getting Started	13
<i>Connection</i>	13
<i>Network Settings</i>	14
<i>Network Discovery</i>	14
<i>Network Security Recommendations</i>	15
Panel Indicators and Appointments	16
<i>Front View</i>	16
<i>Rear View</i>	17
Connecting of DB90-TX	18
<i>Analog Audio Inputs</i>	18
<i>Digital Audio Input</i>	18
<i>LAN Port</i>	18
Operation	19
<i>Network Discovery</i>	19
<i>Access</i>	19
<i>WEB Interface</i>	19
<i>Status</i>	21
<i>DB90-TX Configuration</i>	23
<i>Applying New Settings</i>	23
<i>Network Settings</i>	23
<i>WEB Server Settings</i>	24
<i>SNMP Settings</i>	24
<i>Audio Settings</i>	25
<i>Stream Server Settings</i>	26
<i>RTP Settings</i>	26
<i>Icecast Settings</i>	26
<i>Factory Defaults Settings</i>	27
<i>Network Default Settings</i>	28
<i>WEB Server Default Settings</i>	28
<i>SNMP Default Settings</i>	28
<i>Audio Default Settings</i>	28
<i>Stream Server Default Settings</i>	28
<i>RTP Settings</i>	28
<i>Icecast Settings</i>	28

<i>Hardware Reset</i>	29
<i>Network Default Settings</i>	29
<i>WEB Server Default Settings</i>	29
<i>Rebooting</i>	30
<i>Firmware Update</i>	31
<i>Connecting to the Stream Server</i>	32
UPnP discovery in Local Networks	33
UPnP Activation	34
WARRANTY TERMS AND CONDITIONS	35
Product Registration Card	36

THIS PAGE
IS INTENTIONALLY
LEFT BLANK

Introduction

DEVA Broadcast Ltd. is an international communications and high-technology manufacturing organization, its corporate headquarters and facility located in Burgas, Bulgaria. The company serves the broadcast and corporate markets worldwide – from consumers and small businesses to the largest global organizations. It is dedicated to the research, design, development and provision of advanced products, systems and services. DEVA Broadcast launched its own brand back in 1997 and has nowadays evolved to become known as a market leader and internationally reputed manufacturer of user-friendly, cost-effective and innovative broadcast products.

Creativity and innovation are deeply woven into DEVA Broadcast corporate culture. Through successful engineering, marketing and management our team of dedicated professionals creates future-oriented solutions to improve customers' performance. You may rely that all issues communicated to our crew would be addressed accordingly. We pride ourselves on our pre and post-sales support and purchase services, which along with the outstanding quality of our radio gear have won us due respect and the market authority position.

DEVA Broadcast best-of-breed solutions have become the best sellers for our partners. The strategic partnerships which have been formed with industry leaders during all these years that we have been operating on the broadcasting market, have proved us a reliable business partner and a valuable asset, as our dealers worldwide would confirm. In constant pursuit of precision and long-term satisfaction, DEVA Broadcast enhances the reputation of our partners and clients alike. Furthermore, we have already a proven merit as a credible partner provider.

Our portfolio offers complete line of high quality and competitive products for FM and Digital Radio, Radio Networks, Telecommunication Operators and regulation authorities. For almost two decades of intensive software and hardware development, we have achieved a unique price-performance and endurance of our product lines. Our company's multitude of equipment and services is in line with the latest technologies and key trends. The most recognizable characteristics attributed to DEVA Broadcast products are their clear-cut, streamlined design, easiness of use and cost-effectiveness: simplicity of forms but multiplicity of functions.

For us there is no stage when we deem that we have reached the most satisfactory level in our work. Our engineers are in constant pursuit of new ideas and technologies to be captured in DEVA Broadcast solutions. Simultaneously, a strict control is being exercised at each step of any new development. Experience and hard work are our fundament but the continuous improving process is what we never leave aside. DEVA Broadcast participates on a regular basis in all landmark broadcasting events, not only to promote its products, but to exchange valuable know-how and experience. We are also engaged in international large-scale projects involving radio and audio solutions which makes us even more competitive on the global market.

All DEVA Broadcast products are developed and produced in accordance with the latest ISO 9001 quality control standards.

Typographic conventions

The following table describes important conventions used in the manual.

Convention and Style	Description	Examples
<i>Menu > Sub Menu > Menu Command</i>	A menu item(s) and menu command that you need to click in sequence	Click <i>Settings > General</i>
[Button]	Interface Interactive buttons	Press [OK] to save the changes
NOTE	Important notes and recommendations	NOTE: The notification will appear only once
<u>“Reference Name” on Page XXX</u>	References and links	refer to <u>“New Connection”</u> (see <u>“Monitoring” on page 56</u>)
Example	Used when example text is cited	Example for E-mail Notification: Date: 04 Nov 2013, 07:31:11

General Information

DB90-TX IP Audio Encoder is an integrated audio converter that converts audio signal into a high quality compressed audio stream. The signal can be compressed by HE-AAC, MPEG-1 Layer 3 encoder. DB90-TX also supports uncompressed PCM stream in order to ensure audio transmission without quality loss.

Compression is performed in real time, and the output signal is transmitted directly by IP-based networks. DB90-TX can work with both analog and digital audio signal. No matter how sophisticated, DB90-TX is located in a small and compact housing. All this allows you to quickly and painlessly integrate existing audio systems to the Internet. Developed with the thought of easiness of use, DB90-TX can be managed through a standard web browser, PC, PDA or other device.

APPLICATION

- Audio broadcasting over IP-based networks.
- Point-to-Point Audio Transfer (DB90-RX IP Audio Decoder is required at the opposite site).
- Suitable for professional and consumer use.

PRODUCT FEATURES

- High Quality HE-AAC (v.1 and v.2) and MPEG-1 Layer-3 Compression;
- 32 kHz, 44.1 and 48 kHz sample rates support;
- Up to 56 kbps bitrate for HE-AAC;
- Up to 320 kbps bitrate for MPEG-1 Layer-3;
- 6 LEDs and Phones output for quick diagnostics;
- IP address pronunciation at startup (through the headphones);
- Easy setup via a standard web browser;
- UPnP for easy discovery in Local Networks;
- Shoutcast/Icecast compatible TCP/IP stream;
- Status monitoring via SNMP
- Up to 10 simultaneously connected clients*;

* The actual limit depends on the speed of the link and/or other factors.

TECHNICAL SPECIFICATIONS

AUDIO CODEC	
Codec	HE-AAC (v.1 and v.2), MPEG-1 Layer 3 or raw PCM
Sample rates	32, 44.1 and 48 kHz
Channels	1 or 2
Bitrate	56 kbps (HE-AAC); 320 kbps (MPEG-1); 1536 kbps (PCM);
MPEG-1 LAYER 3 SPECIFIC	
Encoding mode	Mono and stereo, Joint Stereo or Dual Channel
Emphasis	50µs, CCITT J.17 or none
PCM CODEC	
Channels	1 or 2
Bitrate	Up to 3072 kbps
ANALOG AUDIO INPUT	
Connector	2 x RCA, stereo
Type	Unbalanced
Level	+6dBu (max. +8dBu)
Sample rate	96 kHz; Build-in SRC used to produce lower sample rates
Dynamic range	102 dB
DIGITAL AUDIO INPUT	
Connector	RCA
Type	S/PDIF (IEC 60958)
Resampling	Thru build-in sample rate converter
STREAMING SERVER	
Type	Shoutcast / Icecast compatible TCP/IP stream
Codec	Codec AAC, MP3, PCM
Clients limit	Up to 10 simultaneous clients
ICECAST SOURCE CLIENT	
Type	Icecast Source Client
Codec	AAC, MP3, PCM
Count	1
RTP SENDER	
Type	Unicast RTP Sender
Codec	AAC, MP3
Count	1
PHONES AUDIO OUTPUT	
Connector	1/8" (3.5mm) jack, stereo
Type	Headphones
USER INTERFACE	
Indicators	6 LEDs on front panel
Web interface	Full control and status information
NETWORK	
Connector	RJ-45
Type	Ethernet
Device discovery	UPnP support

OPERATING CONDITIONS	
Temperature	-15°C to 55°C
Humidity	< 95%, non-condensing
Altitude	0 to 5000m above sea level
POWER REQUIREMENTS	
Power supply	12V DC, 1A
SIZE AND WEIGHT	
Dimension (W x H x D)	4,17" x 1,3" x 5" (106 x 33 x 128 mm)
Weight	0,44 lbs (0,2 kg)

BLOCK DIAGRAM

A simplified block diagram of DB90-TX IP Audio Encoder is shown below

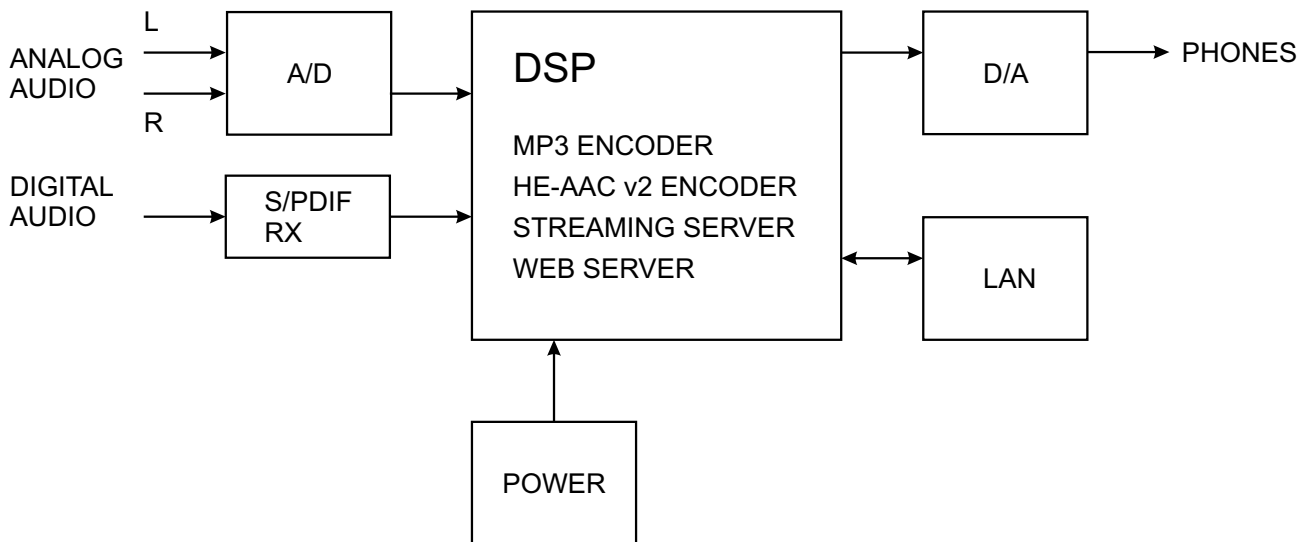

Because of the all-digital, minimalist-discrete-component nature of device circuitry, we have not provided schematic diagrams of the DB90-TX in this Manual. As they say on the back of TV sets:

**NO USER-SERVICEABLE COMPONENTS INSIDE.
 REFER ALL SERVICING TO
 QUALIFIED TECHNICAL PERSONNEL.**

Safety Warning

ALWAYS OBSERVE THE SAFETY PRECAUTIONS.

Careful observance of the safety precautions will help prevent physical injury, damage of the equipment, and extend the equipment life.

- The servicing of electronic equipment should be performed only by qualified personnel;
- Before removing the covers the unit must be switched off and the mains cable unplugged;
- When the equipment is open, the power supply capacitors should be discharged using a suitable resistor;
- Never touch the wires or the electrical circuits;
- Use insulated tools only;
- Never touch the metal semiconductor. They might carry high voltages;
- For removing and installing electronic components, follow the recommendations for handling MOS components.
- Do not remove the factory sticker from the equipment. It contains information as regards the name, serial number and MAC address of the device.
- To join the equipment to the mains supply, use the power cord purchased with the equipment.

Unpacking and inspection

Upon receipt, the equipment should be inspected for possible shipping damages. If such are found or suspected, notify the carrier at once and contact DEVA Broadcast Ltd. The original shipping carton box and packing materials should be kept for possible reuse, in case of return for Warranty repair, for example. Shipping damages as a result of improper packing for return may invalidate the Warranty!

The packing material (plastic bags, polystyrene, nails, etc.) must never be left within reach of children, as these items are potential sources of danger.

IT IS VERY IMPORTANT that the [“Product Registration Card”](#) included in the Manual be completed accurately and returned. This will assure coverage of the terms of the Warranty and it will provide a means of trace in case of lost or stolen equipment. In addition, the user will automatically receive SERVICE OR MODIFICATION INSTRUCTIONS from DEVA Broadcast Ltd.

Mounting

RACK REQUIREMENTS 1U

The unit mounts in a standard 19-inch equipment rack and requires only 1¾ inches (1U) of vertical rack space. In order the painted finish around the mounting holes to be protected, the use of plastic washers is recommended.

RACK REQUIREMENTS COMPACT UNITS

Our customized 1U 19-inch rack accessory provides a professional mounting option for up to three compact size DEVA units. It is made of milled aluminum and finished in black powder coat. Two extra blanking panels and set of mounting screws are provided with each rack bracket kit.

STAND-ALONE DEVICES

DEVA's stand-alone units (Radio Explorer series, BandScanner series, DVB Explorer) do not require additional tools or installation brackets.

Getting Started

In order for the normal operation of the DB90-TX to be guaranteed, you will need fulfill the following conditions:

1. Standard Ethernet 10/100M connection;
2. Correctly assigned Network configuration and device settings.

To make sure that all the conditions are fulfilled please, follow the instructions below.

CONNECTION

1. Install the unit on its operation place;
2. Using the provided power cable, connect the unit to the power supply network;
3. Connect the antenna cable to the RF antenna input connector located on the rear panel of the device;
4. Connect the DB90-TX to the TCP/IP network using direct network cable;
5. **IF GSM OPTION IS SUPPORTED** - Using the connection cable provided, connect the optional GSM modem. In order for better GSM network coverage to be achieved, please select proper place for the GSM antenna.

NOTE: The GSM antenna must be installed far enough from the monitoring devices. The GSM modem radiates RF signal that may cause spurious emissions that will may interfere with the accuracy of the measurements.

NETWORK SETTINGS

After connecting the network cable the Led 'LAN' located on the rear panel must be ON or flashing. The next and most important step for configuration is the adjustment procedure of the Network Communication. The settings shown below are Default Network Settings:

DHCP	Enabled
IP	Assigned by DHCP
Mask	Assigned by DHCP
Gateway	Assigned by DHCP
DNS	Assigned by DHCP
HTTP Port	80

NETWORK DISCOVERY

This is a network setting that defines whether your computer can see (find) other computers and devices on the network and whether other computers on the network can see your computer. By default, Windows Firewall blocks network discovery but you can enable it.

1. Open Advanced sharing settings by clicking the Start button, and then on "Control Panel". In the search box, type "network", click "Network and Sharing Center", and then, in the left pane click "Change advanced sharing settings";
2. Select your current network profile;
3. Click "Turn on network discovery", and then click save changes.

NOTE: If you're prompted for an administrator password or confirmation, type the password, provide confirmation or contact your system administrator.

If you have already enabled this function on your computer DB90-TX will be automatically added to the Device list section. The device will be ready for usage and no additional adjustments will be required except user name and password.

NOTE: If the port is different than the default one (80), it is necessary to specify it, for example:
`http://192.168.1.2:9000`

ATTENTION: Depending on Internet Protocol Settings, the assigned IP address may not be visible outside your local network, thus the device may be accessed only within that network. Consult with your network administrator for the appropriate IP settings.

NETWORK SECURITY RECOMMENDATIONS

1. It is not recommended the DB90-TX to be directly connected to the Internet. This may lead to unregulated access and/or problematic operation of the device. To ensure secure connection, we recommend the device to be installed behind a router with an active firewall.
2. If remote access to the device is needed, we recommend using VPN to the router or the port of the relevant service (WEB, SNMP, Application, etc.) to be properly NAT forwarded.
3. If NAT forward is used, it is highly recommended random ports of your choice to be used. Not the standard ones (80 for WEB, 161 for SNMP, etc.).
4. Using DMZ connection is not recommended.
5. Make sure to change the standard access credentials (usernames and passwords, SNMP communities).

For detailed information as regards the recommendations listed above or need of further instructions, please contact your network administrator.

Panel Indicators and Appointments

FRONT VIEW

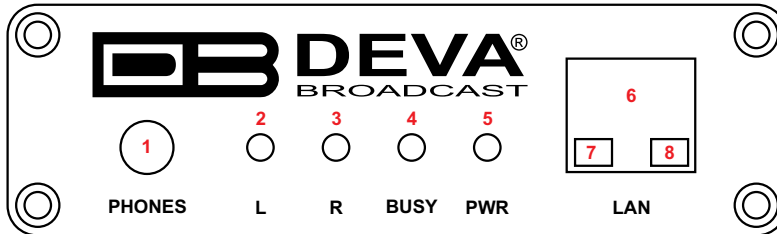

- 1 - Phones Output. The following audio signals are reproduced through the headphones:
 - Voice Announcement of DB90-TX IP Audio Encoder's IP address upon startup;
 - Audio signal from the selected input;
- 2 - Left Channel Level LED Indicator. This LED can be in one of the following states:
 - Off - the channel level is within norms;
 - Blinking – indication of low signal level;
 - Constantly lit – indication of high signal level;
- 3 - Right Channel Level LED Indicator. This LED can in one of the following states:
 - Off - the channel level is within norms;
 - Blinking – indication of low signal level;
 - Constantly lit – indication of high signal level;
- 4 - Connection LED Indicator. This LED can be in one of the following states:
 - Off - NO clients are connected to the encoder;
 - Blinking – at least one client is connected to the streamer;
 - Constantly lit – maximum allowable clients are connected to the streamer ([see “Stream Server Settings” on page 26](#));
- 5 - Power LED Indicator.
- 6 - LAN Port / Internet Input – standard RJ-45 port;
- 7 - Network Activity LED Indicator (RJ-45 built-in);
- 8 - Network Availability LED indicator (RJ-45 built-in);

REAR VIEW

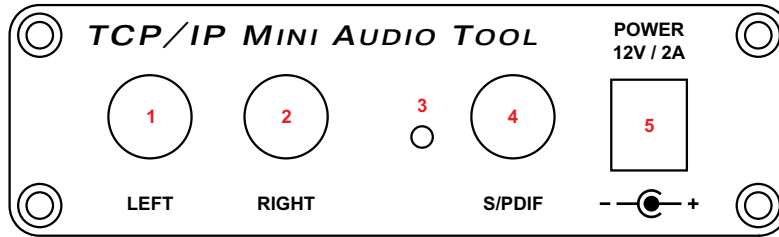

- 1 - Left Line Analog Input – standard RCA female jack;
- 2 - Right Line Analog Input – standard RCA female jack;
- 3 - Factory Defaults Reset button
- 4 - S/PDIF Input – standard RCA female jack;
- 5 - Power Supply (12 V, 1A);

Connecting of DB90-TX

ANALOG AUDIO INPUTS

Using a cable ending with two standard RCA jacks connect the analog signal source to the analog audio inputs of DB90-TX.

WARNING: Do not exceed the maximum input level. This may permanently damage the device.

DIGITAL AUDIO INPUT

Using a cable ending with a standard RCA jacks, connect the S/PDIF signal source to the digital audio input of DB90-TX.

NOTE: As only one input can be managed by the encoder at certain point of time, please select the preferred signal source input – either analog or digital one. Selecting the preferred input can be performed under CONFIGURATION menu ([see “Audio Settings” on page 25](#))

LAN PORT

For normal operation it is necessary the encoder to be connected to a local network or Internet by cable with RJ-45 connector.

Operation

DB90-TX is controlled through a built-in WEB Server and a standard web browser can be used to monitor its status or to make some adjustments. To operate the device you need to know its IP Address. In case you are not aware of it, you can hear it through the headphones when you turn on the device. Alternatively, use the Network discovery feature at Local networks. Then open a new WEB Browser and enter the device IP address in the address field then press [Enter].

NETWORK DISCOVERY

This is a network setting that defines whether your computer can see (find) other computers and devices on the network and whether other computers on the network can see your computer. By default, Windows Firewall blocks network discovery but you can enable it.

1. Open Advanced sharing settings by clicking the Start button, and then on “Control Panel”. In the search box, type “network”, click “Network and Sharing Center”, and then, in the left pane click “Change advanced sharing settings”;
2. Select your current network profile;
3. Click Turn on network discovery, and then click save changes.

NOTE: If you’re prompted for an administrator password or confirmation, type the password, provide confirmation or contact your system administrator.

If you have already enabled this function on your computer DB90-TX will be automatically added to the Device list section. The device will be ready for usage and no additional adjustments will be required except *user name* and *password*.

ACCESS

DB90-TX provides you with a protected access to the device settings. To make the necessary adjustments to the device, please log in as an ADMINISTRATOR. The default values being username: admin, password: pass.

WEB INTERFACE

The Navigational menu and its options are available at the top part of the WEB Interface. The settings window below is divided into two sections - settings (on the left) and help section with brief explanation of the settings. Pointing the mouse cursor on any of the fields in the left part of the screen will open a new window with additional and useful information.

Upon opening the WEB interface, the main Status window will appear. The page contains information on the device's current status.



NOTE: Username and Password may be requested if the Access Control is turned on and a page other than STATUS is selected ([see “WEB Server Settings” on page 24](#)). Defaults values are *user* and *pass*.

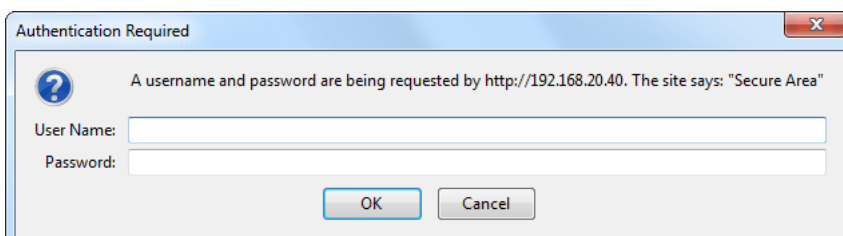



STATUS



Status | Configuration | Factory Defaults | Reboot | Firmware Update

Audio Status:

Left:  -2.7dBFS
 Right:  -3.1dBFS

Network Status:

MAC address: 00:04:A3:1E:45:1F
 Type: Assigned by DHCP
 IP address: 192.168.1.31
 Netmask: 255.255.255.0
 Gateway: 192.168.1.1

Active connections:

Client:	Time connected:
192.168.1.30:4097	032:35:01

Audio Status

Left:
Left peak audio level.

Right:
Right peak audio level.

Network status

MAC:
Shows device's MAC address.

Type:
Shows the way IP address is assigned: DHCP, AutoIP or static.

IP Address:
The assigned IP address.

Netmask:
The assigned subnet mask.



Gateway:
The assigned gateway.

Active connections

Shows a list of all currently connected clients.
 Client's address is in format *IP:Port*.
 Time connected is in format *hh:mm:ss*.

Live data

Click on the icon to toggle live data ON/OFF.

 - live data is ON.
 - live data is OFF.

Deva Broadcast Ltd. © 2012 Model: DB90-TX • Serial: DB90TX110705003

This page contains information regarding:

- Input Signal Level;
- Network Settings;
- List of Active Connections;

Level of the input signal and the list of active connections are updated dynamically which makes it possible to remotely monitor encoder's operation.

Under Network Status are shown MAC address and current IP address, Network mask and Gateway and the method in which they have been assigned:

- Static Allocation Settings
- Allocated by DHCP server
- Automatically generated

The last option uses AutoIP to generate a unique IP address. This option is activated automatically when the device is set to use DHCP server ([see “Network Settings” on page 23](#)), but such server is not available.

The list of Active Connections provides information for the currently connected clients. Shown are the IP address and local port of each client. Link duration is visible as well.

In the upper right corner is located LIVE DATA icon. Clicking on the icon will toggle live data ON and OFF as follows:



- live data is ON



- live data is OFF.

DB90-TX CONFIGURATION

Applying New Settings

In order the applied settings to be used press the [Save] button, placed on the bottom left part of the screen.



The screenshot shows the configuration page for the DB90-TX device. The top navigation bar includes 'Status', 'Configuration' (selected), 'Factory Defaults', 'Reboot', and 'Firmware Update'. The 'Network' tab is active, with 'IP Audio' as a sub-tab. The interface is divided into two main sections: 'General' and 'Network settings'.

General Settings:

- DHCP:** Enabled Disabled
- IP Address:**
- Netmask:**
- Gateway:**
- WEB server:**
 - Port:**
 - Username:**
 - Password:**
- SNMP:**
 - SNMP MIB File:**
 - Agent:** Enabled Disabled
 - Agent Port:**
 - Manager Port:**
 - Agent ID:**
 - Community:**
 - Manager IP:**

A 'Save' button is located at the bottom of the General settings section.

Network settings (Informational):

- DHCP:** Enable or disable DHCP client. The DHCP client is used to automatically obtain the network settings. *Default: Enabled*
- IP Address:** Static IP address. Not used if DHCP client is enabled. *Example: 192.168.0.2*
- Netmask:** Static subnet mask. Not used if DHCP client is enabled. *Example: 255.255.255.0*
- Gateway:** Static gateway. Not used if DHCP client is enabled. *Example: 192.168.0.1*
- Web settings:**
 - Port:** TCP port of the web server. *Default: 80*
 - Username:** User name for the web server. It is used to restrict the access to all configuration pages. If both Username and Password are left blank no security is used. Up to 15 alpha-numeric characters.
 - Password:** Password for the web server. It is used to restrict the access to all configuration pages. If both Username and Password are left blank no security is used. Up to 15 alpha-numeric characters.

The footer of the interface displays 'Deva Broadcast Ltd. © 2012' and 'Model: DB90-TX • Serial: DB90TX110705003'.

Network Settings

- DHCP – as DHCP Client is used to automatically obtain the Network Settings it can be enabled or disabled.
- IP Address – a field where static IP address is to be inserted in case that DHCP client is not used. Example: 192.168.0.2.
- Netmask – a field where Static Subnet Mask is to be inserted. This parameter is not used if DHCP Client is enabled. Example for Netmask is: 255.255.255.0.
- Gateway – a field where Static Gateway is to be inserted. This parameter is not used if DHCP Client is enabled. Example for Gateway is: 192.168.0.1.

NOTE: If the encoder's IP address is changed, it is necessary to enter the new IP address in your browser.

WEB Server Settings

- Port – this is the TCP port of the WEB Server. Default value is 80.
- Username – user name for the WEB Server. Default value is user.
- Password – Password for the WEB Server. Default value is pass.

NOTE: You can define Username only, Password only or both of them. If both Username and Password are left blank, NO security is used.

SNMP Settings

SNMP MIB File: Press the Download button to download DB90-TX SNMP MIB file.

NOTE: The MIB file may change from one firmware revision to the other. Downloading this file from the device ensures that you have the proper MIB file.

Specify Agent ID, Agent Port, Read/Write Communities, Manager IP and Manager Port.

NOTE: Agent ID is used to identify the device among others when a SNMP notification is send.
Agent - enables/disables SNMP Agent.

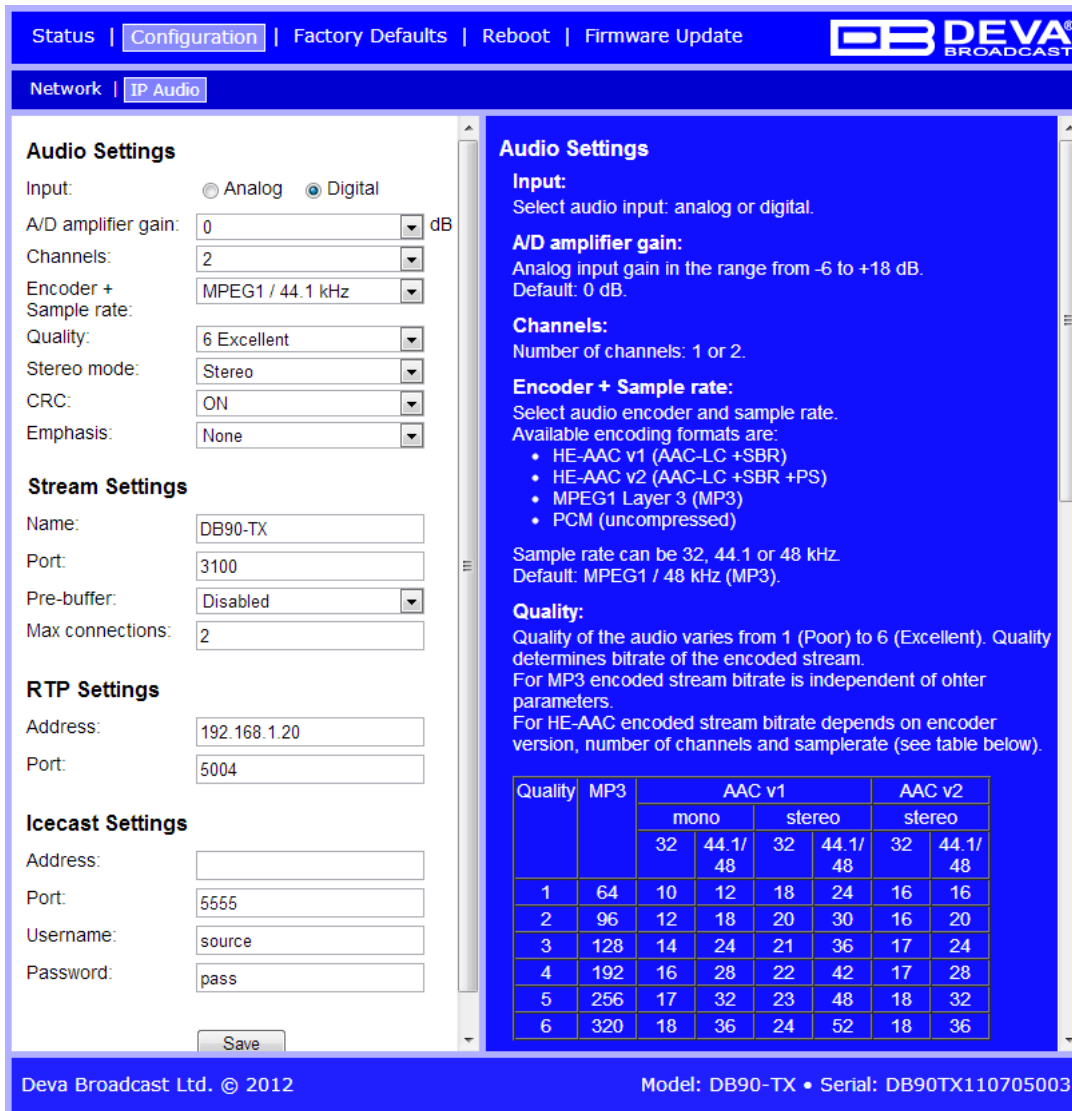

Audio Settings

Input: Analog Digital

A/D amplifier gain: 0 dB

Channels: 2

Encoder + Sample rate: MPEG1 / 44.1 kHz

Quality: 6 Excellent

Stereo mode: Stereo

CRC: ON

Emphasis: None

Stream Settings

Name: DB90-TX

Port: 3100

Pre-buffer: Disabled

Max connections: 2

RTP Settings

Address: 192.168.1.20

Port: 5004

Icecast Settings

Address:

Port: 5555

Username: source

Password: pass

Audio Settings

Input:
Select audio input: analog or digital.

A/D amplifier gain:
Analog input gain in the range from -6 to +18 dB.
Default: 0 dB.

Channels:
Number of channels: 1 or 2.

Encoder + Sample rate:
Select audio encoder and sample rate.
Available encoding formats are:

- HE-AAC v1 (AAC-LC +SBR)
- HE-AAC v2 (AAC-LC +SBR +PS)
- MPEG1 Layer 3 (MP3)
- PCM (uncompressed)

Sample rate can be 32, 44.1 or 48 kHz.
Default: MPEG1 / 48 kHz (MP3).

Quality:
Quality of the audio varies from 1 (Poor) to 6 (Excellent). Quality determines bitrate of the encoded stream.
For MP3 encoded stream bitrate is independent of other parameters.
For HE-AAC encoded stream bitrate depends on encoder version, number of channels and samplerate (see table below).

Quality	MP3	AAC v1				AAC v2	
		mono		stereo		stereo	
		32	44.1/48	32	44.1/48	32	44.1/48
1	64	10	12	18	24	16	16
2	96	12	18	20	30	16	20
3	128	14	24	21	36	17	24
4	192	16	28	22	42	17	28
5	256	17	32	23	48	18	32
6	320	18	36	24	52	18	36

Deva Broadcast Ltd. © 2012 Model: DB90-TX • Serial: DB90TX110705003

Audio Settings

- Input – select analog or digital input to be used.
- A/D Amplifier Gain - Analog input gain in the range from -6 to +18 dB. Default level is 0 dB.
- Channels – select number of the input channels (1 or 2). If only one channel is selected, then the Left one is used.
- Encoder + Sample Rate – select audio encoder and sample rate.

Available encoding formats are:

- HE-AAC v1 (AAC-LC +SBR)
- HE-AAC v2 (AAC-LC +SBR +PS)
- MPEG1 Layer 3 (MP3)
- PCM (uncompressed)
- Quality – Audio quality varies from 1 (Poor) to 6 (Excellent). Quality determines bitrate of the encoded stream. For MP3 encoded stream bitrate is independent of other parameters. For HE-AAC encoded stream bitrate depends on encoder version, number of channels and sample rate (see table below):

Quality	MP3	AAC v1				AAC v2	
		mono		stereo		stereo	
		32 kHz	44.1/48 kHz	32 kHz	44.1/48 kHz	32 kHz	44.1/48 kHz
1	64	10	12	18	24	16	16
2	96	12	18	20	30	16	20
3	128	14	24	21	36	17	24
4	192	16	28	22	42	17	28
5	256	17	32	23	48	18	32
6	320	18	36	24	52	18	36

Please note all rates are in kbps.

NOTE: Quality does not apply to PCM stream. For PCM stream bitrate is calculated by the following equation: (sample rate)*(Number of channels)*16, [bps].

- Stereo mode – selecting stereo mode. Supported modes are Stereo, Joint Stereo or Dual Channels.

NOTE: This parameter applies only to MP3 stream.

- CRC - selecting whether MP3 stream to contain information on error detection.

Note: This parameter applies only to MP3 stream.

- Emphasis – selecting the emphasis to be applied. Supported values are 50µs, CCITT J.17 and NO emphasis.

NOTE: This parameter applies only to MP3 stream.

Stream Server Settings

- Name – this is the encoder’s name displayed as name of the stream.
- Port – a field where TCP port of the stream server must be inserted. Default value is 5000.
- Pre-buffer – initial amount of data sent to the client. Large value decreases startup delay caused by buffering on the client side. This also introduces latency in the audio. Latency is bitrate dependent and can be estimated by the formula:

$$\text{Latency} = (\text{PreBuffer} \times 8) / \text{BitRate}, [\text{sec}].$$
 Default value is 96k.
- Max connections – maximum number of simultaneous connected clients. This value can be in the range from 1 to 10. Default value is 2.

RTP Settings

- Address – URL or IP Address of the RTP Receiver.
- Port – UDP port of the RTP Receiver.

Icecast Settings

- Address – URL or IP Address of the Icecast Receiver.
- Port – TCP port of the Icecast Receiver.
- Username – Username for Authentication with Icecast Receiver.
- Password – Password for Authentication with Icecast Receiver.

FACTORY DEFAULTS SETTINGS



To restore the DB90-TX to its factory defaults, follow the steps listed below:

- Press the “Restore” button.
- A new window will appear:

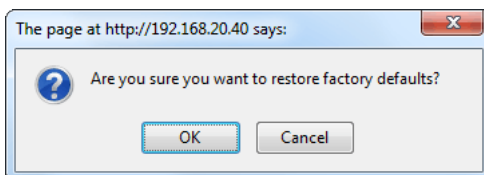

- Confirm that you want to restore factory defaults.
- Wait for the process to complete.

All the settings will be restored to their factory defaults except the Network Settings, which will remain the same.

Upon completion of the process DB90-TX settings will have the following values:

Network Default Settings

All General Network Settings will remain unchanged.

WEB Server Default Settings

All WEB Server Settings will remain unchanged.

SNMP Default Settings

- Agent : Disabled
- Agent Port: 161
- Community: DEVA90
- Manager IP: 0.0.0.0
- Manager Port: 162
- Agent ID: 0

Audio Default Settings

- Input: analog
- A/D amplifier gain: 0 dB
- Channels: 2
- Encoder + Sample rate: MPEG 1/48 kHz
- Quality: 6 Excellent
- Stereo mode: Stereo
- CRC: ON
- Emphasis: None

Stream Server Default Settings

- Name: DB90-TX
- Port: 5000
- Pre-buffer: 96k
- Max connections:2

RTP Settings

- Port: 5004

Icecast Settings

- Port: 5555
- Username: source
- Password: pass

HARDWARE RESET

This process will fully restore DB90-TX to its Factory Defaults, including the Network settings. Hardware Reset can be done by following the next steps:

- Disconnect the power supply cable from the unit.
- Locate the RESET button on Rear panel.
- Press and hold the RESET button.
- Connect the power supply cable to the unit.
- Keep the RESET button hold until the POWER led starts blinking.
- Release the RESET button.
- Wait for DB90-TX to reboot with the factory default settings.

Upon completion of the process DB90-TX settings will have the following values:

Network Default Settings

- DHCP: enabled

WEB Server Default Settings

- Port: 80
- Username: user
- Password: pass

All other settings will have the factory default values described in chapter [“Factory Defaults Settings”](#).

NOTE: After the process is completed and the DHCP client is enabled, the DB90-TX will obtain IP Address from the DHCP server shortly.

ATTENTION: Please note that the WEB Server’s Port, Username and Password will be changed, so it is possible the page not to be loaded after restoring factory defaults. You may be asked to re-enter the encoder’s address and/or username and password.

REBOOTING



To reboot the DB90-TX, follow the steps listed below:

- Press the “Reboot” button.
- The following warning window will appear:

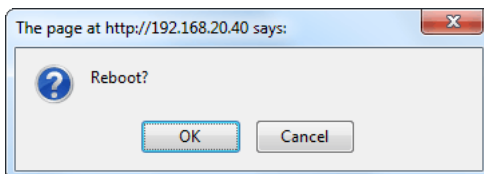

- Confirm that you want to reboot the encoder.
- Wait for the process to complete.

FIRMWARE UPDATE

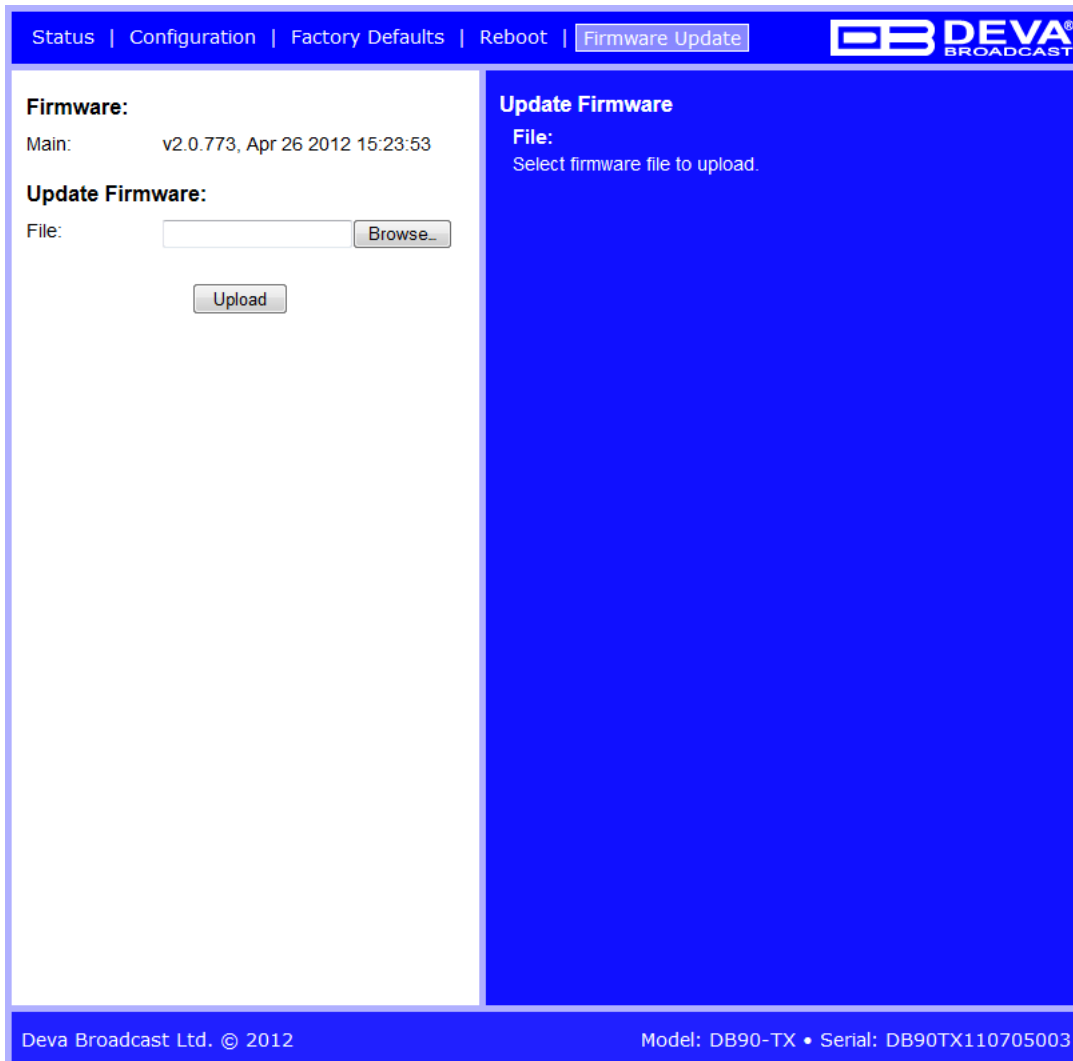

To update the encoder's firmware, please follow the next steps:

- Select the new firmware file.
- Press the "Upload" button.
- The following warning window will appear:

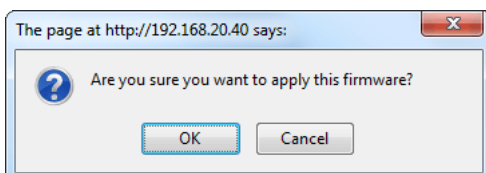

- Wait for the process to complete

IMPORTANT NOTE: The MIB file may vary from one firmware revision to another. Downloading this file from the device, guarantees that you have the proper MIB file.

CONNECTING TO THE STREAM SERVER

The steps listed below will guide you through the process of how to listen to the stream audio:

- Open an audio player supporting streaming audio
- Select “Play URL”
- Insert device’s address and port. For example: <http://192.168.0.2:5000/> .
- Wait to be connected

UPnP discovery in Local Networks

DB90-TX implements UPnP which lets you easily find it in your local network. For this purpose your system should have UPnP enabled ([see “UPnP Activation” on page 34](#)). To discover the device follow the next steps:

- Connect the device to the local network.
- Open “My Network Places” on your computer.
- Find the decoder’s icon.
- Double click it to open the DB90-TX web interface.

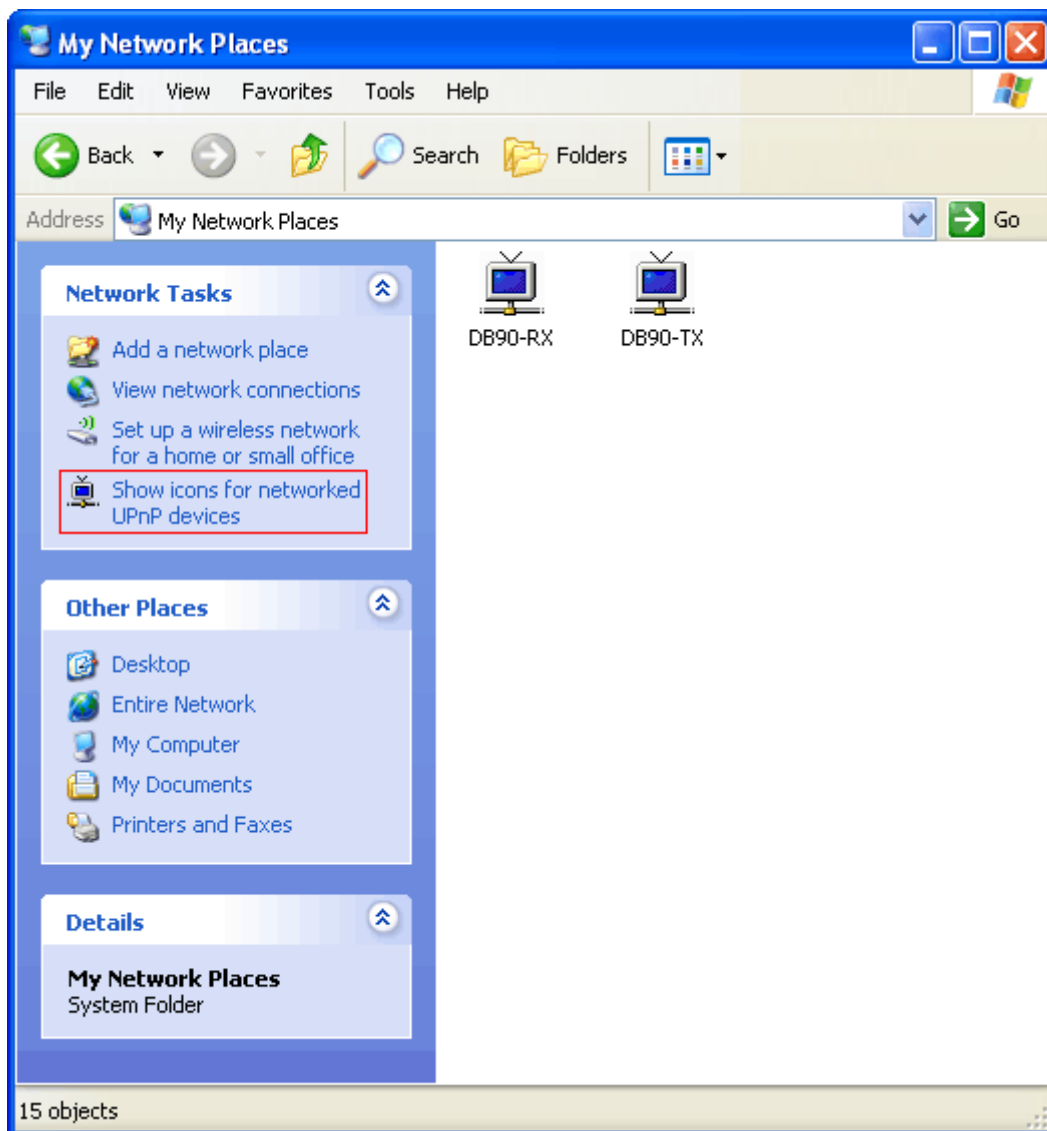

UPnP Activation

NOTE: The following explanations apply to Windows XP SP2 or SP3! If you use another operating system, please contact your system administrator.

Open “My Network Places”. If you have the caption displayed in the picture below, click on it. Then click “Yes” and wait for the process to complete. Now you should see the device. If you still have troubles finding the device, please see

<http://support.microsoft.com/kb/941206> or contact your system administrator.

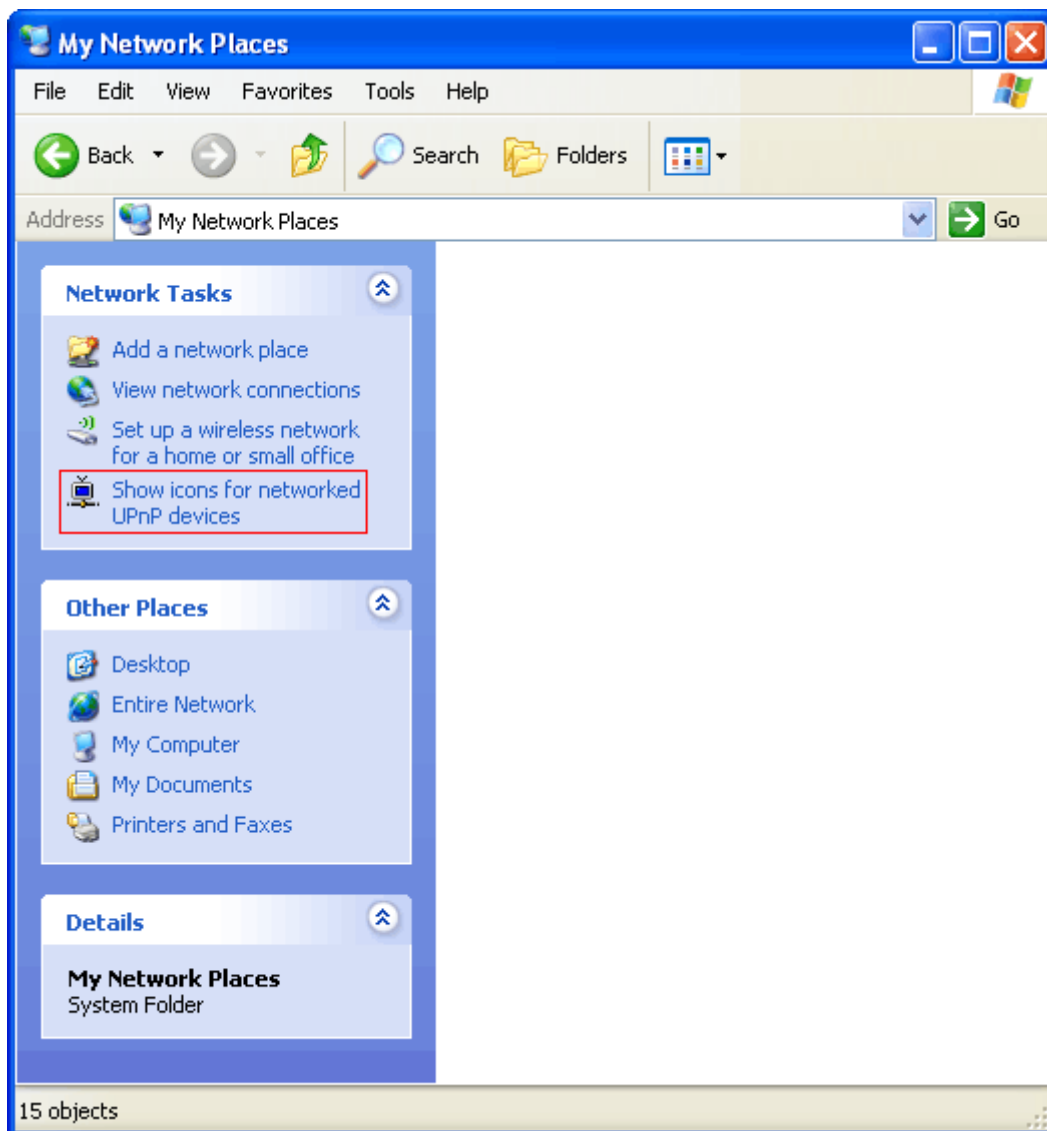

WARRANTY TERMS AND CONDITIONS

I. TERMS OF SALE: DEVA Broadcast Ltd. products are sold with an understanding of “full satisfaction”; that is, full credit or refund will be issued for products sold as new if returned to the point of purchase within 30 days following their receipt, provided that they are returned complete and in an “as received” condition.

II. CONDITIONS OF WARRANTY: The following terms apply unless amended in writing by DEVA Broadcast Ltd.

A. The Warranty Registration Card must be completed and returned to DEVA Broadcast Ltd. within 10 days of delivery. Product registration can also be done digitally at <https://www.devabroadcast.com/members/product-registration>, after registering on our website, within 10 days of delivery.

B. This Warranty applies only to products sold “as new.” It is extended only to the original end-user and may not be transferred or assigned without prior written approval by DEVA Broadcast Ltd.

C. This Warranty does not apply to damage caused by improper mains settings and/or power supply.

D. This Warranty does not apply to damage caused by misuse, abuse, accident or neglect. This Warranty is voided by unauthorized attempts at repair or modification, or if the serial identification label has been removed or altered.

III. TERMS OF WARRANTY: DEVA Broadcast Ltd. products are warranted to be free from defects in materials and workmanship.

A. Any discrepancies noted within TWO YEARS of the date of purchase will be repaired free of charge, or the equipment will be replaced with a new or remanufactured product at DEVA Broadcast Ltd. option.

B. Parts and labor for factory repair required after the two-year Warranty period will be billed at prevailing prices and rates.

IV. RETURNING GOODS FOR FACTORY REPAIR:

A. Equipment will not be accepted for Warranty or other repair without a Return Material Authorization (RMA) number issued by DEVA Broadcast Ltd. prior to its return. An RMA number may be obtained by placing an RMA request at <https://www.devabroadcast.com/rma>. The number should be prominently marked on the outside of the shipping carton.

B. Equipment must be shipped prepaid to DEVA Broadcast Ltd. Damage sustained as a result of improper packing for return to the factory is not covered under terms of the Warranty and may occasion additional charges.

V. UPDATES TO THE TERMS OF SERVICE:

For the most up-to-date, valid, and accurate terms, conditions, and product documentation, please visit the official DEVA Broadcast Ltd. website downloads section at <https://www.devabroadcast.com/downloads/deva-documents>. Printed documents may not reflect recent amendments. Reviewing the current online versions ensures you have the latest information.



PRODUCT REGISTRATION CARD

- All fields are required, or warranty registration is invalid and void

Your Company Name _____

Contact _____

Address Line 1 _____

Address Line 2 _____

City _____

State/Province _____ ZIP/Postal Code _____

Country _____

E-mail _____ Phone _____ Fax _____

Which DEVA Broadcast Ltd. product did you purchase? _____

Product Serial # _____

Purchase date ____ / ____ / ____ Installation date ____ / ____ / ____

Your signature*

*Signing this warranty registration form you are stating that all the information provided to DEVA Broadcast Ltd. are truth and correct. DEVA Broadcast Ltd. declines any responsibility for the provided information that could result in an immediate loss of warranty for the above specified product(s).

Privacy statement: DEVA Broadcast Ltd. will not share the personal information you provide on this card with any other parties.