

MAINTENANCE AND OPERATION  
INSTRUCTION MANUAL

# DB9009-TX

Second Generation  
Multi Protocol Audio over IP Encoder



# Contents

<b>Introduction</b> .....	<b>5</b>
<b>Typographic conventions</b> .....	<b>6</b>
<b>General Information</b> .....	<b>7</b>
<b>Product Features</b> .....	<b>8</b>
<i>Technical Specifications</i> .....	9
<b>Panel Indicators and Appointments</b> .....	<b>11</b>
<i>Front Panel</i> .....	11
<i>Rear Panel</i> .....	12
<i>GPIO Connectors Pinouts</i> .....	13
<i>GPI Port Pinouts</i> .....	13
<i>GPI 1 Example Connection</i> .....	13
<i>RS-232 Port Pinouts</i> .....	13
<i>Block diagram</i> .....	14
<b>Safety Warning</b> .....	<b>15</b>
<b>Operating Recommendations</b> .....	<b>16</b>
<b>Unpacking and inspection</b> .....	<b>17</b>
<b>Mounting</b> .....	<b>17</b>
<i>Rack Requirements 1U</i> .....	17
<i>Rack Requirements Compact Units</i> .....	17
<i>Stand-Alone Devices</i> .....	17
<b>Getting Started</b> .....	<b>18</b>
<i>Connection</i> .....	18
<i>Network Settings</i> .....	19
<i>Network Discovery</i> .....	19
<i>Network Security Recommendations</i> .....	20
<b>Basic Setup</b> .....	<b>21</b>
<i>Analog Audio Inputs</i> .....	21
<i>Digital Audio Inputs</i> .....	21
<i>LAN port</i> .....	21
<i>RS-232 COM Port</i> .....	21
<i>GPI port</i> .....	21
<b>Front Panel - OLED Display, Navigational &amp; Soft Buttons</b> .....	<b>22</b>
<i>Display</i> .....	22
<i>Header Area</i> .....	22
<i>Soft buttons</i> .....	23
<i>Main screen working area</i> .....	23
<b>Operating Modes and Pages</b> .....	<b>24</b>
<i>Home Page</i> .....	24
<i>Graphs page</i> .....	25
<i>Levels page</i> .....	27
<i>Settings page</i> .....	28
<i>Settings menu title</i> .....	28
<i>Navigation area</i> .....	28
<i>Numerical parameter (INT). Represents numerical value.</i> .....	29
<i>Enumerated parameter (ENUM).</i> .....	29

<i>IP address (IP). Represents IPv4 address.....</i>	30
<i>IP port (PORT). Represents IP port.....</i>	30
<i>String (STR). Represents string.....</i>	31
<i>Date (DATE). Represent date information. ....</i>	31
<i>Time (TIME). Represent time information. ....</i>	32
<i>Timer (TIMER). Represents relative time interval.....</i>	32
<i>Status page .....</i>	33
<i>About page .....</i>	34
<b>WEB Interface.....</b>	<b>35</b>
<i>Network Discovery.....</i>	35
<i>Access.....</i>	35
<b>WEB Interface Menu pages .....</b>	<b>36</b>
<i>Status .....</i>	36
<i>Settings .....</i>	37
<i>Input .....</i>	38
<i>Encoding .....</i>	39
<i>IP Audio.....</i>	41
<i>IP Audio Server.....</i>	41
<i>IP Audio Sender 1/2/3.....</i>	41
<i>General.....</i>	43
<i>Network .....</i>	44
<i>Network .....</i>	44
<i>E-mail .....</i>	44
<i>HTTP Server .....</i>	45
<i>FTP Server .....</i>	45
<i>SNMP Agent .....</i>	45
<i>GPIO .....</i>	46
<i>Other .....</i>	47
<i>Firmware Update .....</i>	47
<i>Storage .....</i>	47
<i>System Log .....</i>	47
<i>Factory Defaults .....</i>	47
<i>Reboot Device.....</i>	47
<b>APPENDIX A .....</b>	<b>48</b>
<i>RDS: Europe vs America .....</i>	48
<i>The RDS System .....</i>	48
<b>APPENDIX B.1 .....</b>	<b>49</b>
<i>PTY Code Description Used in RBDS Mode – North America.....</i>	49
<b>APPENDIX B.2 .....</b>	<b>50</b>
<i>PTY Code Description Used in RDS Mode – Europe, Asia .....</i>	50
<b>APPENDIX C .....</b>	<b>51</b>
<i>How should I configure the connection between my DEVA Device and an FTP Client?</i>	51
1. <i>FTP Server Settings .....</i>	51
2. <i>IP Router and Port Translation Settings.....</i>	51
3. <i>Example of FTP Client (FileZilla) Settings .....</i>	52
<b>WARRANTY TERMS AND CONDITIONS.....</b>	<b>53</b>
<b>Product Registration Card.....</b>	<b>54</b>

THIS PAGE  
IS INTENTIONALLY  
LEFT BLANK

## Introduction

DEVA Broadcast Ltd. is an international communications and high-technology manufacturing organization, its corporate headquarters and facility located in Burgas, Bulgaria. The company serves the broadcast and corporate markets worldwide – from consumers and small businesses to the largest global organizations. It is dedicated to the research, design, development and provision of advanced products, systems and services. DEVA Broadcast launched its own brand back in 1997 and has nowadays evolved to become known as a market leader and internationally reputed manufacturer of user-friendly, cost-effective and innovative broadcast products.

Creativity and innovation are deeply woven into DEVA Broadcast corporate culture. Through successful engineering, marketing and management our team of dedicated professionals creates future-oriented solutions to improve customers' performance. You may rely that all issues communicated to our crew would be addressed accordingly. We pride ourselves on our pre and post-sales support and purchase services, which along with the outstanding quality of our radio gear have won us due respect and the market authority position.

DEVA Broadcast best-of-breed solutions have become the best sellers for our partners. The strategic partnerships which have been formed with industry leaders during all these years that we have been operating on the broadcasting market, have proved us a reliable business partner and a valuable asset, as our dealers worldwide would confirm. In constant pursuit of precision and long-term satisfaction, DEVA Broadcast enhances the reputation of our partners and clients alike. Furthermore, we have already a proven merit as a credible partner provider.

Our portfolio offers complete line of high quality and competitive products for FM and Digital Radio, Radio Networks, Telecommunication Operators and regulation authorities. For almost two decades of intensive software and hardware development, we have achieved a unique price-performance and endurance of our product lines. Our company's multitude of equipment and services is in line with the latest technologies and key trends. The most recognizable characteristics attributed to DEVA Broadcast products are their clear-cut, streamlined design, easiness of use and cost-effectiveness: simplicity of forms but multiplicity of functions.

For us there is no stage when we deem that we have reached the most satisfactory level in our work. Our engineers are in constant pursuit of new ideas and technologies to be captured in DEVA Broadcast solutions. Simultaneously, a strict control is being exercised at each step of any new development. Experience and hard work are our fundament but the continuous improving process is what we never leave aside. DEVA Broadcast participates on a regular basis in all landmark broadcasting events, not only to promote its products, but to exchange valuable know-how and experience. We are also engaged in international large-scale projects involving radio and audio solutions which makes us even more competitive on the global market.

All DEVA Broadcast products are developed and produced in accordance with the latest ISO 9001 quality control standards.

## Typographic conventions

The following table describes important conventions used in the manual.

Convention and Style	Description	Examples
<i>Menu &gt; Sub Menu &gt; Menu Command</i>	A menu item(s) and menu command that you need to click in sequence	Click <i>Settings &gt; General</i>
[Button]	Interface Interactive buttons	Press [OK] to save the changes
<b>NOTE</b>	Important notes and recommendations	<b>NOTE:</b> The notification will appear only once
<u>“Reference Name” on Page XXX</u>	References and links	refer to <u>“New Connection”</u> (see <u>“Monitoring” on page 56</u> )
Example	Used when example text is cited	Example for E-mail Notification: Date: 04 Nov 2013, 07:31:11

## General Information

DB9009-TX is a second generation multi protocol Audio over IP Encoder, designed in line with the latest market requirements. Designed to be user friendly in terms of operation, this device is perfect for both inexperienced and professional broadcasters alike. DB9009-TX can work with either analog or digital audio signal. The compressed output signal is directly transmitted over the IP-based networks to one or more compatible IP Audio players or decoders.

Since DEVA's products are manufactured to meet the highest standards, the encoding of the audio sources into high quality configurable format, is made in real time by HE-AAC Versions 1 and 2 or MPEG-1 Layer 3. This in combination with the lossless uncompressed PCM stream, unaffected by the variable network conditions, guarantees long distance audio transmission without quality loss.

This affordable device impresses with its new and precise milled front panel, aluminum sheet body, OLED Graphical Display and Intuitive navigation menu. The status monitoring of the audio levels (visualized in bar graphs) and the connection information and configuration, have never been so easy, thanks to the OLED Graphical Display and the Intuitive Navigation Menu. The Soft Buttons indicators placed on the bottom side of the OLED display are used for navigation through the menus and for quick access to the parameters, modes, functions and as well as for altering their values.

Upon selecting the audio source, the encoded in real time audio will be instantly send to the network. The new and improved DB9009-TX can act simultaneously as an Icecast compatible Server, Icecast source client or Real Time Protocol (RTP) sender. Through the RS-232 port, this device could be easily transformed from an Ethernet to a serial Redirector, enabling quick integration of the existing audio systems to the Internet.

DB9009-TX offers exceptional features at an affordable price. Its trouble-free operation guarantees long term reliability and easy firmware updates, directly on the field or remotely via the free of charge, password protected WEB Interface. Once installed on its operation place, this device will be ready for the 24/7/365 operation.

## Product Features

- Excellent Audio Performances
- Easy to read OLED Graphical Display
- Intuitive Navigation Menu
- High Quality HE-AAC (v.1 and v.2) and MPEG-1 Layer 3 Codecs
- 32 kHz, 44.1 and 48 kHz sample rates support
- Up to 320 kbps under MPEG-1 Layer 3
- Up to 56 kbps under HE-AAC
- Shoutcast/Icecast compatible TCP/IP stream server (10 clients)
- Icecast Source Client functionality
- RTP Audio Compatible
- 5 LEDs and Phones output for quick diagnostics
- IP address pronunciation at startup (through the headphones)
- Full Control and easy setup via a standard web browser
- Configuration and Monitoring via SNMP Ver.2C
- UPnP for easy discovery in Local Networks
- Ethernet to RS-232 Redirector



## TECHNICAL SPECIFICATIONS

<b>AUDIO ENCODER</b>	
Count	2 user selectable plus 1 fixed (PCM)
Codec	HE-AAC (v.1 and v.2), MPEG-1 Layer 3 or raw PCM
Sample rates	32 kHz, 44.1 kHz and 48 kHz
Channels	1 or 2
Bit Rates	Up to 88 kbps (HE-AAC); Up to 320 kbps (MPEG-1); Up to 1536 kbps (PCM)
<b>MPEG-1 LAYER 3 SPECIFIC</b>	
Encoding mode	Mono and Stereo, Joint Stereo or Dual Channel
Emphasis	50µs, CCITT J.17 or none
<b>IP AUDIO SERVER</b>	
Type	SHOUTcast/Icecast compatible TCP/IP stream server
Codec	Any of the available
Count	Up to 10 simultaneously connected clients
<b>ICECAST SOURCE CLIENT</b>	
Type	Icecast Source Client
Codec	Any of the available
Count	Up to 3 independent streams
<b>SHOUTCAST SOURCE</b>	
Type	SHOUTcast v1 Source
Codec	Any of the available
Count	Up to 3 independent streams
<b>RTP SENDER</b>	
Type	Unicast/Multicast RTP Sender
Codec	Any of the available
Count	Up to 3 independent streams
<b>ANALOG AUDIO INPUT</b>	
Connector	2 x XLR, stereo
Type	Balanced
Level	+18 dBu (max. +19dBu), user selectable
Distortion	<0.01% THD+N
Sample rate	32 kHz, 44.1 kHz and 48 kHz
Dynamic range	102 dB
<b>DIGITAL AUDIO INPUT</b>	
Connector	XLR
Type	AES/EBU
Resampling	Thru build-in sample rate converter

<b>FRONT PANEL</b>	
Display	High-resolution OLED
Status Indicators	5 LEDs
Headphones	1/4" (6.3mm) phones jack
<b>USER INTERFACE</b>	
Indicators	OLED display + 5 LEDs on front panel
Web interface	Full control and status information
Connector	RJ-45
Type	Ethernet
Device discovery	UPnP support
<b>OPERATING CONDITIONS</b>	
Temperature	-15°C to 55°C
Humidity	< 95%, non-condensing
Altitude	0 to 5000m above sea level
<b>POWER REQUIREMENTS</b>	
Connector	IEC320
Power supply	100-240V / 50-60 Hz / 25W
<b>SIZE AND WEIGHT</b>	
Dimensions (W;H;D)	485 x 44 x 180 mm
Shipping Weight	540 x 115 x 300 mm / 2.6kg

## Panel Indicators and Appointments

### FRONT PANEL



1. Phones Output - The following audio signals are reproduced through the headphones:
  - Voice Announcement of DB9009-TX IP Audio Encoder's IP address upon startup;
  - Audio signal from the selected input.
2. LED Indicators
  - Power
  - Network
  - IP Audio
  - MP3 Audio
  - Memory
3. OLED Screen
4. Soft buttons

## REAR PANEL

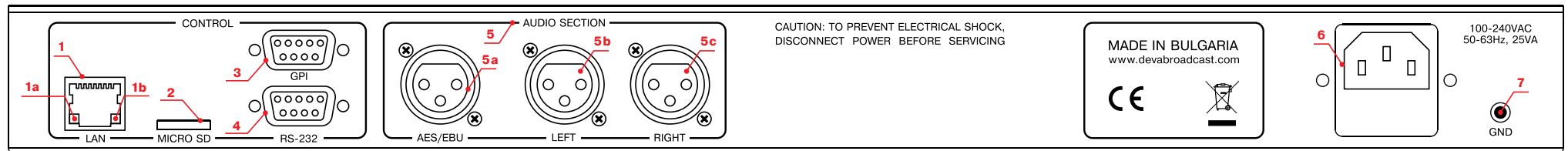

- 1- LAN Port / Internet Input – standard RJ-45 port:
- 1a - Network Activity LED Indicator (RJ-45 built-in);
- 1b - Network Availability LED Indicator (RJ-45 built-in);
- 2 - SD Card;
- 3 - GPI;
- 4 - RS-232 Serial COM Port - DB-9 Female Connector;
- 5 - Audio section:
- 5a - AES/EBU - Digital Audio Input – Balanced XLR Female;
- 5b - Left - Analog Audio Input – Balanced XLR Female;
- 5c - Right - Analog Audio Input – Balanced XLR Female;
- 6 - Power Supply;
- 7 - GND.

## GPIO CONNECTORS PINOUTS

### GPI Port Pinouts

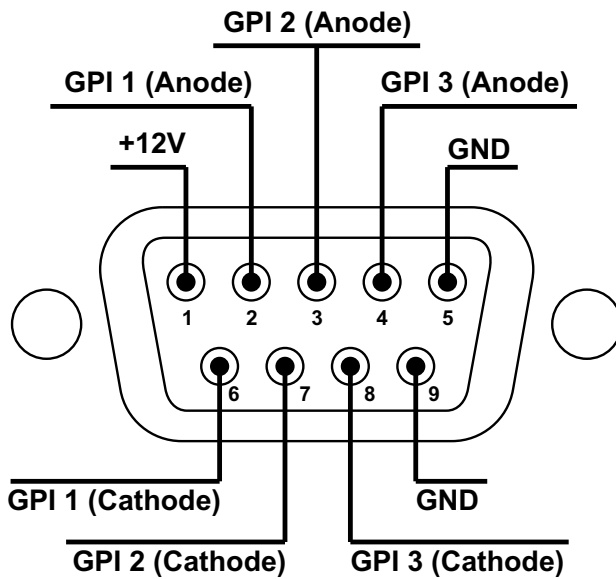

$I_F = 10 \text{ mA}$   
 $I_{Fmax} = 50 \text{ mA}$

### GPI 1 Example Connection

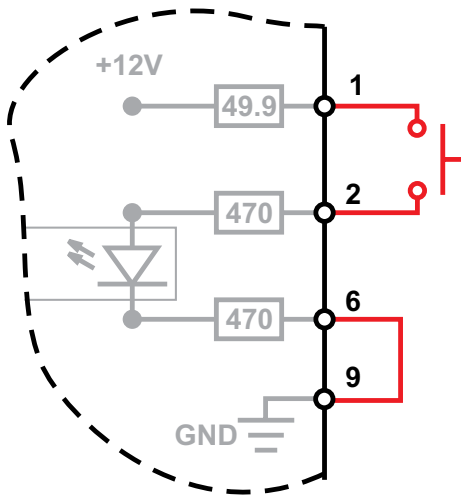

### RS-232 Port Pinouts

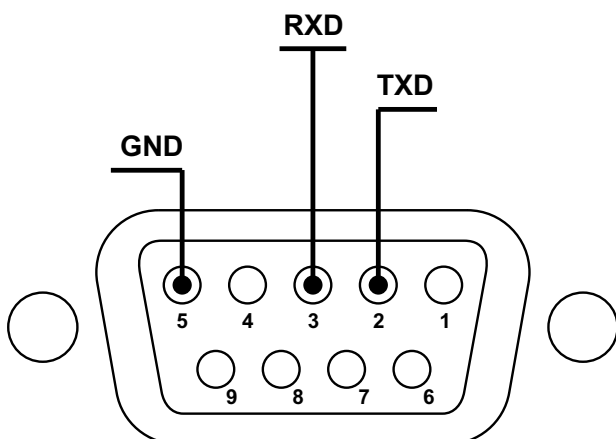

## BLOCK DIAGRAM

A simplified block diagram of DB9009-TX IP Audio Encoder is shown below:

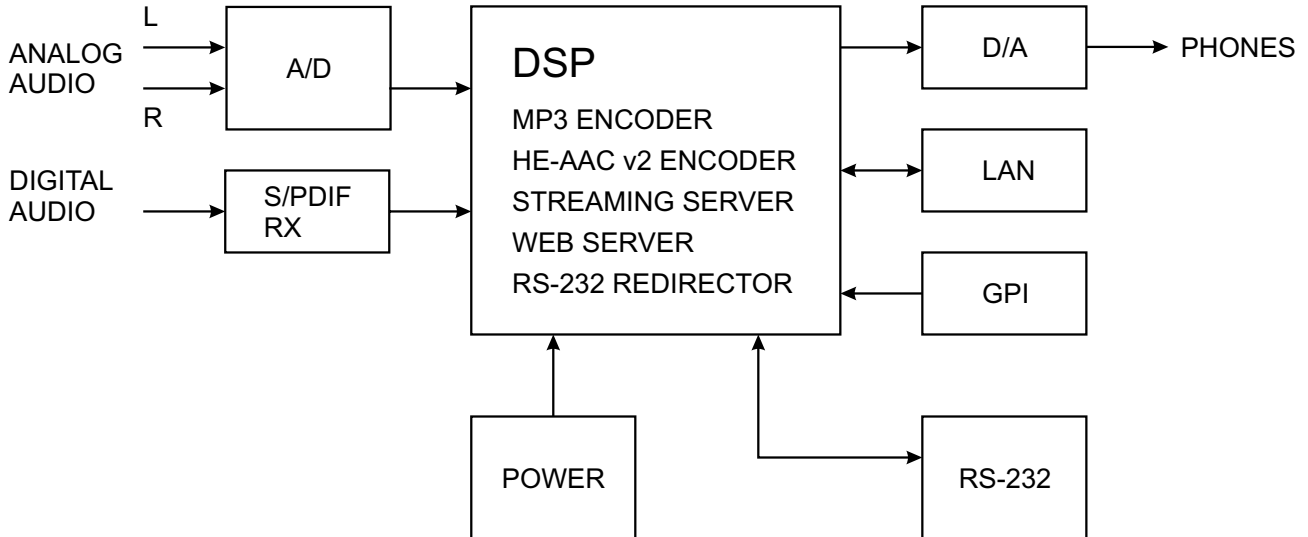

Because of the all-digital, minimalist-discrete-component nature of device circuitry, we have not provided schematic diagrams of the DB9009-TX in this Manual. Please, note that:

**NO USER-SERVICEABLE COMPONENTS INSIDE.  
REFER ALL SERVICING TO  
QUALIFIED TECHNICAL PERSONNEL.**

## Safety Warning

### **ALWAYS OBSERVE THE SAFETY PRECAUTIONS.**

Careful observance of the safety precautions will help prevent physical injury, damage of the equipment, and extend the equipment life.

- The servicing of electronic equipment should be performed only by qualified personnel;
- Before removing the covers the unit must be switched off and the mains cable unplugged;
- When the equipment is open, the power supply capacitors should be discharged using a suitable resistor;
- Never touch the wires or the electrical circuits;
- Use insulated tools only;
- Never touch the metal semiconductor. They might carry high voltages;
- For removing and installing electronic components, follow the recommendations for handling MOS components.
- Do not remove the factory sticker from the equipment. It contains information as regards the name, serial number and MAC address of the device.
- To join the equipment to the mains supply, use the power cord purchased with the equipment.

**ATTENTION:** The device has an internal Lithium battery. Do not try to re-charge this battery! In case the battery needs to be changed, please contact us for detailed instructions and information of the battery type.

## Operating Recommendations

To ensure normal operation of the DEVA unit, we recommend following the instructions listed below.

- Install the unit in places with good air conditioning. The unit is designed to operate within the ambient temperature range of 10 to 50°C. The equipment rack should be ventilated in order for the device to keep its internal temperature below the maximum ambient temperatures;
- We do not recommend installation in rooms with high humidity, dusty places or other aggressive conditions;
- Although the device is intended to be installed closed to exciters or transmitters, we do recommend the device to be located away from abnormally high RF fields.
- Use only checked power supply cables. We strongly recommend the usage of shielded cables;
- Connect the DEVA unit to reliable power supply sources only. In case of unstable power supply, please use Uninterruptible Power Supply (UPS);
- Use the device only with its top cover on to avoid electromagnetic anomalies. Otherwise, this may cause problems with the normal functionality of the unit;
- To ensure normal remote operation of the unit, make sure to connect the device to a good quality Internet connection;
- For the normal operation of your DEVA device, check if the network settings past through all the required data traffic.



## Unpacking and inspection

Upon receipt, the equipment should be inspected for possible shipping damages. If such are found or suspected, notify the carrier at once and contact DEVA Broadcast Ltd. The original shipping carton box and packing materials should be kept for possible reuse, in case of return for Warranty repair, for example. Shipping damages as a result of improper packing for return may invalidate the Warranty!

**The packing material (plastic bags, polystyrene, nails, etc.) must never be left within reach of children, as these items are potential sources of danger.**

**IT IS VERY IMPORTANT** that the [“Product Registration Card”](#) included in the Manual be completed accurately and returned. This will assure coverage of the terms of the Warranty and it will provide a means of trace in case of lost or stolen equipment. In addition, the user will automatically receive SERVICE OR MODIFICATION INSTRUCTIONS from DEVA Broadcast Ltd.

## Mounting

### **RACK REQUIREMENTS 1U**

---

The unit mounts in a standard 19-inch equipment rack and requires only 1 $\frac{3}{4}$  inches (1U) of vertical rack space. In order the painted finish around the mounting holes to be protected, the use of plastic washers is recommended.

### **RACK REQUIREMENTS COMPACT UNITS**

---

Our customized 1U 19-inch rack accessory provides a professional mounting option for up to three compact size DEVA units. It is made of milled aluminum and finished in black powder coat. Two extra blanking panels and set of mounting screws are provided with each rack bracket kit.

### **STAND-ALONE DEVICES**

---

DEVA's stand-alone units (Radio Explorer series, BandScanner series, DVB Explorer) do not require additional tools or installation brackets.

## Getting Started

In order for the normal operation of the DB9009-TX to be guaranteed, you will need fulfill the following conditions:

1. Standard Ethernet 10/100M connection;
2. Correctly assigned Network configuration and device settings.

To make sure that all the conditions are fulfilled please, follow the instructions below.

### CONNECTION

---

1. Install the unit on its operation place;
2. Using the provided power cable, connect the unit to the power supply network;
3. Connect the antenna cable to the RF antenna input connector located on the rear panel of the device;
4. Connect the DB9009-TX to the TCP/IP network using direct network cable;
5. **IF GSM OPTION IS SUPPORTED** - Using the connection cable provided, connect the optional GSM modem. In order for better GSM network coverage to be achieved, please select proper place for the GSM antenna.

**NOTE:** The GSM antenna must be installed far enough from the monitoring devices. The GSM modem radiates RF signal that may cause spurious emissions that will may interfere with the accuracy of the measurements.

## NETWORK SETTINGS

---

After connecting the network cable the Led 'LAN' located on the rear panel must be ON or flashing. The next and most important step for configuration is the adjustment procedure of the Network Communication. The settings shown below are Default Network Settings:

DHCP	Enabled
IP	Assigned by DHCP
Mask	Assigned by DHCP
Gateway	Assigned by DHCP
DNS	Assigned by DHCP
HTTP Port	80

## NETWORK DISCOVERY

---

This is a network setting that defines whether your computer can see (find) other computers and devices on the network and whether other computers on the network can see your computer. By default, Windows Firewall blocks network discovery but you can enable it.

1. Open Advanced sharing settings by clicking the Start button, and then on "Control Panel". In the search box, type "network", click "Network and Sharing Center", and then, in the left pane click "Change advanced sharing settings";
2. Select your current network profile;
3. Click "Turn on network discovery", and then click save changes.

**NOTE:** If you're prompted for an administrator password or confirmation, type the password, provide confirmation or contact your system administrator.

If you have already enabled this function on your computer DB9009-TX will be automatically added to the Device list section. The device will be ready for usage and no additional adjustments will be required except user name and password.

**NOTE:** If the port is different than the default one (80), it is necessary to specify it, for example:  
`http://192.168.1.2:9000`

**ATTENTION:** Depending on Internet Protocol Settings, the assigned IP address may not be visible outside your local network, thus the device may be accessed only within that network. Consult with your network administrator for the appropriate IP settings.

## **NETWORK SECURITY RECOMMENDATIONS**

---

1. It is not recommended the DB9009-TX to be directly connected to the Internet. This may lead to unregulated access and/or problematic operation of the device. To ensure secure connection, we recommend the device to be installed behind a router with an active firewall.
2. If remote access to the device is needed, we recommend using VPN to the router or the port of the relevant service (WEB, SNMP, Application, etc.) to be properly NAT forwarded.
3. If NAT forward is used, it is highly recommended random ports of your choice to be used. Not the standard ones (80 for WEB, 161 for SNMP, etc.).
4. Using DMZ connection is not recommended.
5. Make sure to change the standard access credentials (usernames and passwords, SNMP communities).

For detailed information as regards the recommendations listed above or need of further instructions, please contact your network administrator.

## Basic Setup

### ANALOG AUDIO INPUTS

---

Using a cable ending with two standard XLR jacks connect the analog signal source to the analog audio inputs of DB9009-TX.

**WARNING:** Do not exceed maximum input level. This may permanently damage the device.

### DIGITAL AUDIO INPUTS

---

Using a cable ending with a standard XLR jacks connect the S/PDIF signal source to the digital audio input of DB9009-TX.

**NOTE:** As only one input at a time can be managed by the encoder at certain point of time, please select the preferred signal source input – either analog or digital one. Selecting the preferred input can be performed under CONFIGURATION menu ([see “Input” on page 38](#)).

### LAN PORT

---

For normal operation it is necessary the encoder to be connected to a local network or Internet by cable with RJ-45 connector.

### RS-232 COM PORT

---

Using standart DB-9 cable connect DB9009-TX to any RS-232 compatible equipment.

### GPI PORT

---

The current audio source can be selected/forced using this GPI port.

## Front Panel - OLED Display, Navigational & Soft Buttons

### DISPLAY

The DB9009-TX's OLED display has three function areas: Header, Soft Buttons and Main Screen Working area.

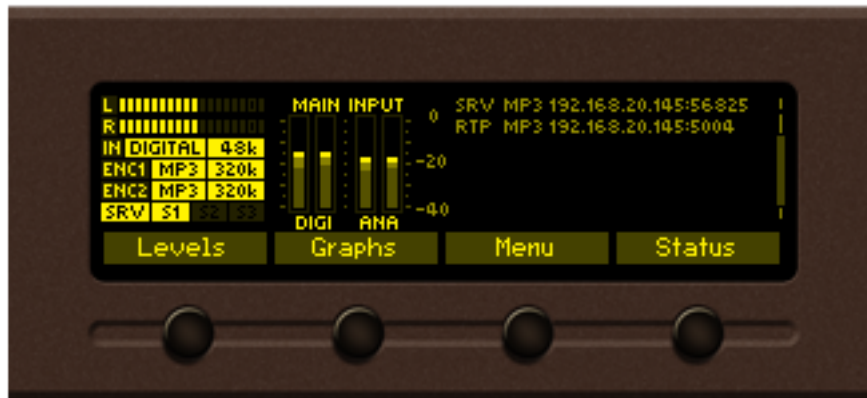

### HEADER AREA

Header is located on the left quarter of the screen. Depending on contents of working area the header may contains the following items:

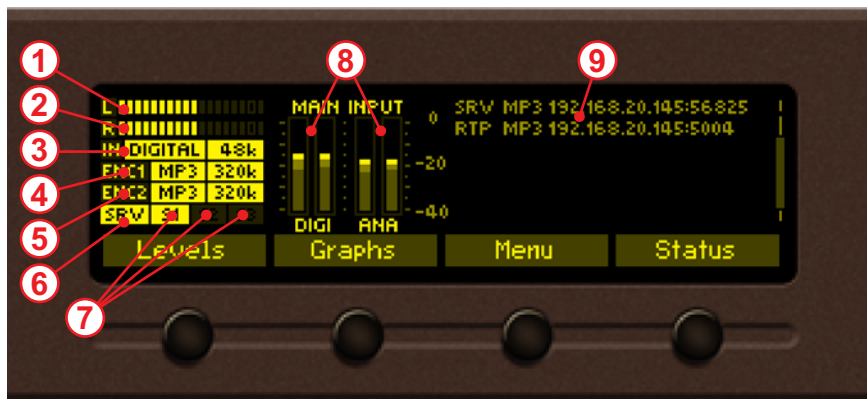

1. Indicator to show the Left signal audio level
2. Indicator to show the Right signal audio level
3. Selected input - analog or digital
4. Settings applied to Encoder 1
5. Settings applied to Encoder 2
6. SRV (IP Audio Server) – indicates if there are any clients connected.
7. S1, S2, S3 (IP Audio Sender 1/2/3) – indicates if the IP Audio Sender is currently active.
8. Main input (Analog and Digital) levels
9. Connections list – displays a list of all active connections.

## SOFT BUTTONS

---

Soft buttons are located on the bottom side of the OLED Display making possible direct transition from some of the pages to another page. In such cases the inscription of a specified Soft Button corresponds to the page it is linked with. Most of the pages have the same or similar functionality distinctive segments (areas). Pressing of a specified Soft button causes a visual effect of pressing the appropriate Soft button on the OLED Display. Function, Menu Page, Parameter to be changed, etc., that are linked to a specified Soft button will appear as inscription on the button.

For example:

- Levels page
- Graphs page
- Menu page
- Status page

**NOTE:** On some pages the Header and Soft button area may be hidden.

## MAIN SCREEN WORKING AREA

---

The Main part of the OLED Screen is the place where the information changes dynamically. The Menu Screen (shown below) appears after a short pressing of the [OK] Navigational Button. The DB9009-TX's Menu Page contains selectable icons and buttons for selecting modes and functionalities of this device. Pressing [Left] and [Right] arrow buttons changes icon selection of the Menu Page. An icon is selected when it receives the rectangle focus frame around it. Short pressing of the [OK] button on selected icon will make a transition to corresponding page. On figure below the Graphs icon is selected.



The following Operating Modes and Pages can be selected using the Navigational Buttons:

- Home page
- Graphs page
- Levels page
- Settings page
- Status page
- About page

## Operating Modes and Pages

### HOME PAGE

---

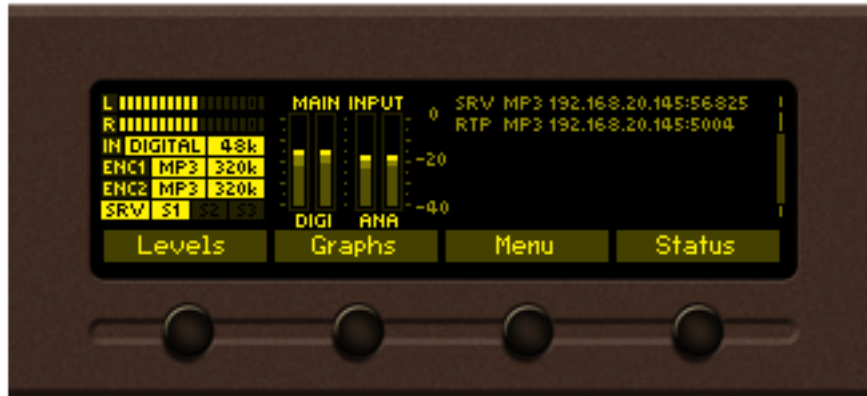

Immediately after power-up and boot process of DB9009-TX, the Home page is shown on the display.

Transition to Home page can be made from any page where Soft Button is available. On the default home screen the Header area is shown ([see "Header Area" on page 22](#)). Shown are also the most important parameters. If there are no active connections present, the Home page will look like this:

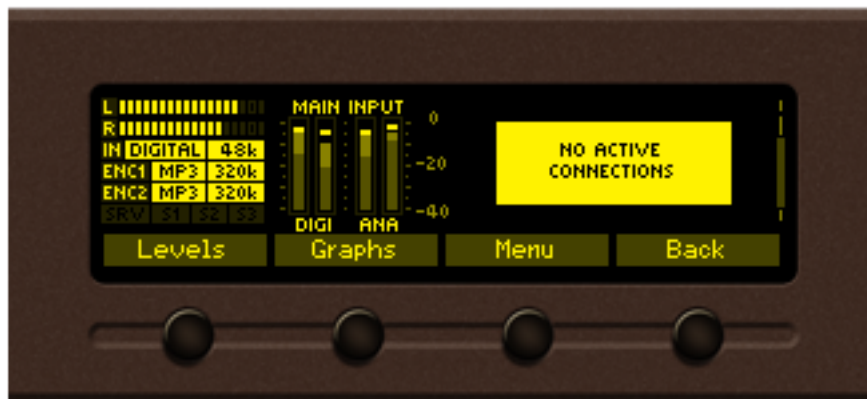



## GRAPHS PAGE

Press [SB2] or select Graphs icon from Menu page and short press [OK] button on it. The transition to Graphs page will be made.

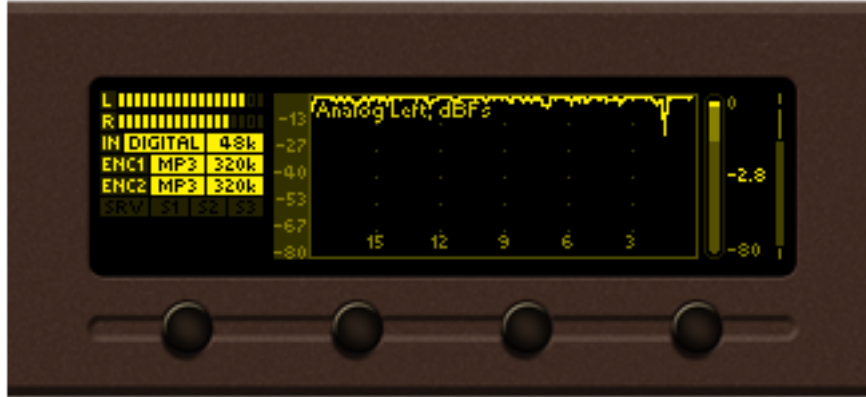

Graph page represents the value deviation of measured parameters in time. The X axis of the data plot area is elapsed time in seconds. New peak value sample is added to data graph on every 125 ms (20 seconds for MPX power). Up to 20 seconds of measurement history is available for each parameter. The most recent moment in time is on the right side of the graph. The name and the unit for Y axis of currently measured parameter is displayed on top left corner of data plot. On the right side of the display a bargraph indicator is used to display momentary value of selected parameter. The low and high limits of measured range are also available in shaded color.

Button assignments:

[OK] – Transition to Main menu page.

[LEFT]/[RIGHT] – No assignment.

[UP]/[DOWN] – Changes currently displayed parameter history. Following parameters are available for observation:



*Analog Left audio level from -80 to 0 in dBFs;*

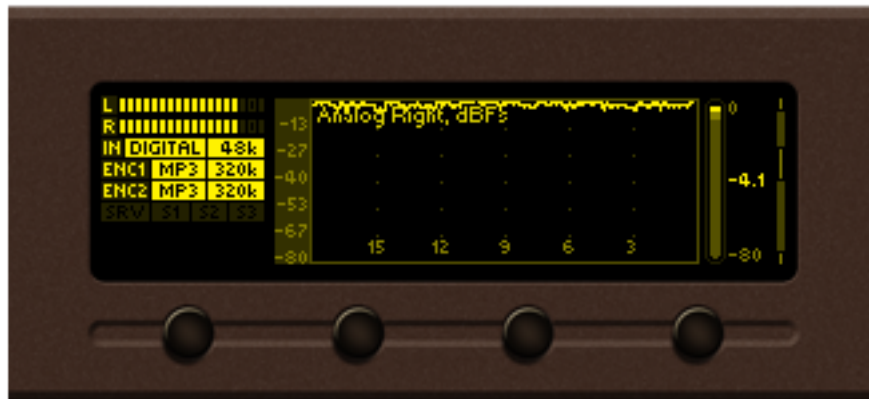

*Analog Right audio level from -80 to 0 in dBFs;*



*Digital Left audio level from -80 to 0 in dBFs;*

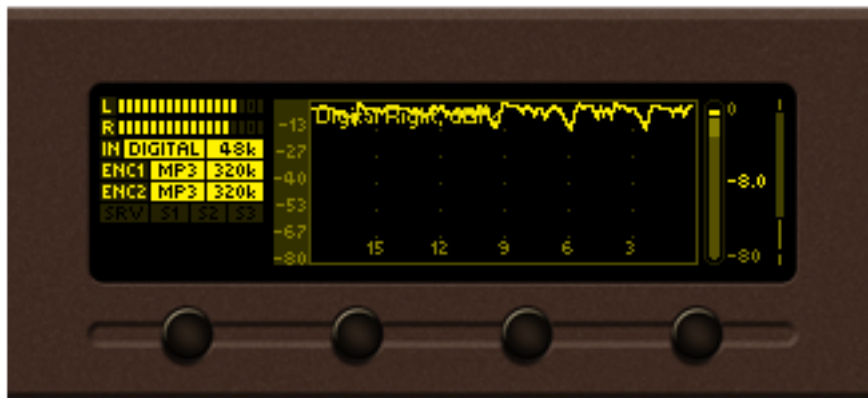

*Digital Right audio level from -80 to 0 in dBFs;*

## LEVELS PAGE

Press [SB1] or select Level icon from Menu page and short press [OK] button on it, transition to Levels page will be made.



Levels page shows bargraph representation of different parameters, measured by DB9009-TX. The parameters are shown in group of four. Each bargraph displays averaged momentary value in highlighted color number, minimum and maximum peak values. Shaded color number found on the left and right bottom edges denotes the measurement range of the parameter. The name and measurement unit of the parameter is shown above corresponding bargraph.

## SETTINGS PAGE

Select Settings icon from Menu page and short press [OK] button on it. The transition to Settings page will be made.

The device settings are organized as hierarchical tree menu (Settings menu). Similar parameters are grouped in sections (branches). The overall view of the Settings menu is shown on the figure below.



“Audio” section (branch) from the root Settings menu is selected



“Main Source” parameter from “Audio” branch is selected

There is several areas in the Settings menu screen:

### Settings menu title

– shows the path to currently selected menu item. Note that parameter name should be considered in the context of settings menu title. For example Settings>Network>Email.

### Navigation area

– the selection of certain branches / parameters is made here. The selected item is drawn in highlighted color. The names of the branches or parameters are listed on the right side of the navigation area. The value of the parameter is shown on the right – against the parameter name. Since branches have no values associated with them the tree dots are shown instead. This indicates a sublevel branch or parameter.

Button assignments:

[OK] – Acts differently depending on current selection. If selection is:

- Menu branch – the transition to selected branch is made and the branch items are listed in navigation area;
- Menu parameter – the value of that parameter is highlighted and edit mode is entered;

- Menu complex parameter (such as Alarm) – the parameter editor is shown and edit mode is activated;
  - [UP]/[DOWN] – If edit mode is active – changes the value of the selected parameter. Otherwise will move selection in corresponding direction up/down.
  - [LEFT]/[RIGHT] – Changes selection within parameter value in edit mode. See examples below.
  - [SB4] – Back one level or cancel menu mode.

There is several parameter types available in DB9009-TX. The way of editing depends of that type. Following is description of parameter types. Every parameter has several properties, change step, unit, default value, permitted range for its value and so on.

**Numerical parameter (INT). Represents numerical value.**

Example:



Button assignments for INT in edit mode:

- [OK] – Accept the value and exits edit mode.
- [UP]/[DOWN] – Changes the value of the parameter with one step increment/decrement. The value always stays in permitted parameter range.
- [SB4] – Discards the value and cancels edit mode.

**Enumerated parameter (ENUM).**

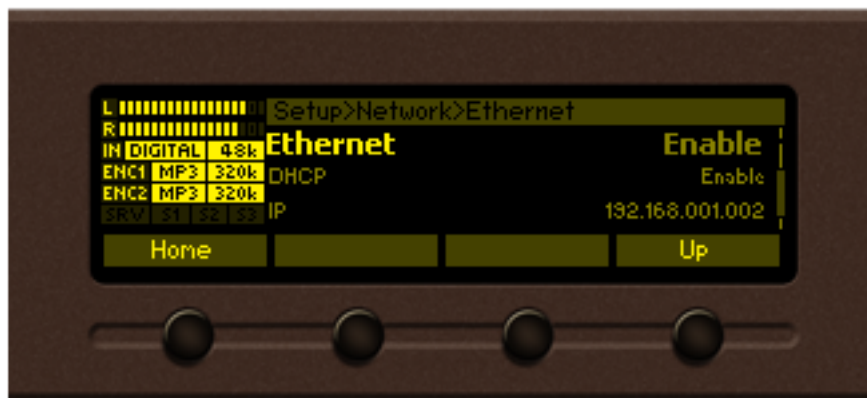

Represent selection of one value from set of predefined enumerated values. Example: The value can be changed between “Enable” and “Disable” position. Button assignments for ENUM in edit mode:

- [OK] – Accept the value and exits edit mode.
- [UP]/[Down] – Cycles through possible value positions. The value always stays in permitted

parameter range.

[SB4] – Discards the value and cancels edit mode.

### IP address (IP). Represents IPv4 address.

Example:

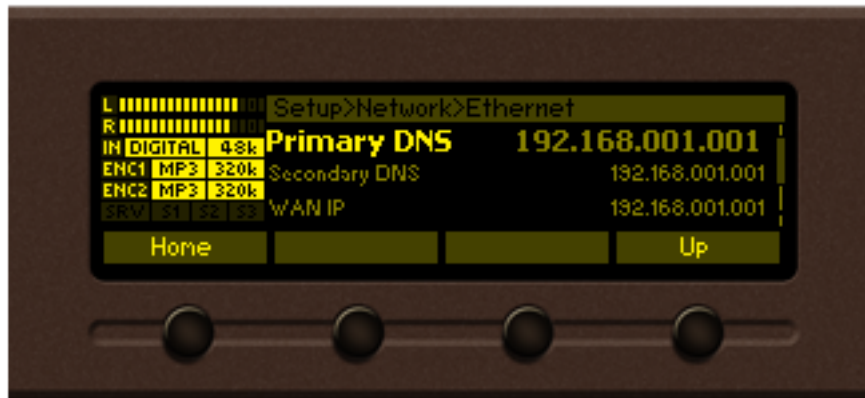

Button assignments for IP in edit mode:

[OK] – Accept the value and exits edit mode.

[UP]/[DOWN] – Cycles through possible values for selected (highlighted background) segment of IP address. The value always stays in permitted parameter range.

[LEFT]/[RIGHT] – Selects previous/next segment from the IP address.

[SB4] – Discards altered value and cancels edit mode.

### IP port (PORT). Represents IP port.



Button assignments for IP port in edit mode: See IP address description.

### String (STR). Represents string.



Button assignments for STR in edit mode:

[OK] – Accept the value and exits edit mode. Note that certain String, like e-mail addresses, are validated prior acceptance. If validation fails the message box is displayed and edit mode is not left after message box confirmation. For example:

[UP]/[DOWN]– Cycles through possible values for selected (highlighted background) string character. There is certain limitation in permitted charset depending from string context.

[LEFT]/[RIGHT]– Selects previous/next character from the string. If [RIGHT] button is pressed with the last character selected the new space character is added automatically at the end of the string **User Name user**. On [LEFT] button press the trailing spaces are removed automatically.

[SB2] – Inserts white space before selected character.

**User Name user** - before [SB2] press

**User Name user** - after [SB2] press

[SB3] – Deletes selected character.

**User Name user** - before [SB3] press

**User Name us** - after [SB3] press

[SB4] – Discards altered value and cancels edit mode.

### Date (DATE). Represent date information.



Button assignments for DATE in edit mode:

[OK] – Accept the value and exits edit mode.

[UP]/[DOWN]– Cycles through possible values for selected (highlighted background) segment of parameter value. The value always stays in permitted parameter range.

[LEFT]/[RIGHT]– Selects previous/next segment from the parameter value.

[SB4] – Discards altered value and cancels edit mode.

**Time (TIME). Represent time information.**

Button assignments for TIME in edit mode: See DATE description.

**Timer (TIMER). Represents relative time interval.**

Button assignments for TIMER in edit mode:

[OK] – Accept the value and exits edit mode.

[UP]/[DOWN]– Increments/decrements value with one step. The unit of the value changes automatically from seconds to minutes and vice-versa.

[SB4] – Discards altered value and cancels edit mode.



## STATUS PAGE

Information on the device's status, IP address, etc. can be found here.

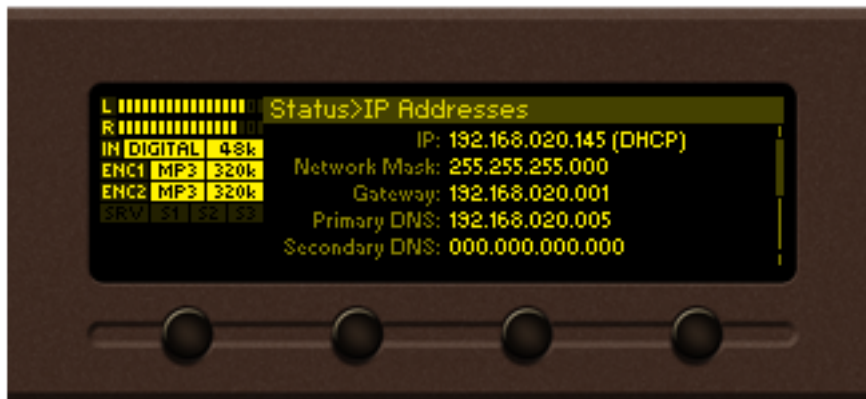

## ABOUT PAGE

---

Information on the device's model and contacts of the manufacturer can be found here.



## WEB Interface

DB9009-TX is controlled through a built-in WEB Server and a standard web browser can be used to monitor its status or to make some adjustments. To operate the device you need to know its IP Address. In case you are not aware of it, you can hear it through the headphones when you turn on the device. Alternatively, use the Network discovery feature at Local networks

Open a new WEB Browser and enter the device IP address in the address field then press [Enter]. Due to the inability of some WEB browsers to read the IP address format displayed on the screen of the device, the numbers included in the IP address must be written without the leading zeros. For example: 192.168.020.095 must be written as 192.168.20.95

A window that requires username and password will appear. Default values being Username: *user* or *admin*, Password: *pass*

## NETWORK DISCOVERY

---

This is a network setting that defines whether your computer can see (find) other computers and devices on the network and whether other computers on the network can see your computer. By default, Windows Firewall blocks network discovery but you can enable it.

1. Open Advanced sharing settings by clicking the Start button, and then on “Control Panel”. In the search box, type “network”, click “Network and Sharing Center”, and then, in the left pane click “Change advanced sharing settings”;
2. Select your current network profile;
3. Click Turn on network discovery, and then click save changes.

**NOTE:** If you’re prompted for an administrator password or confirmation, type the password, provide confirmation or contact your system administrator.

If you have already enabled this function on your computer DB9009-TX will be automatically added to the Device list section. The device will be ready for usage and no additional adjustments will be required except user name and password.

## ACCESS

---

DB9009-TX provides you with a protected access to the device settings. You can choose between two types of log in:

1. As an ADMINISTRATOR – it will give you full control over the settings (username: *admin*, password: *pass*);
2. As a USER – this type of log-in will allow you only to monitor the device (username: *user*, password: *pass*).

In order to make the necessary adjustments to the device, please log in as an ADMINISTRATOR.

## WEB Interface Menu pages

### STATUS

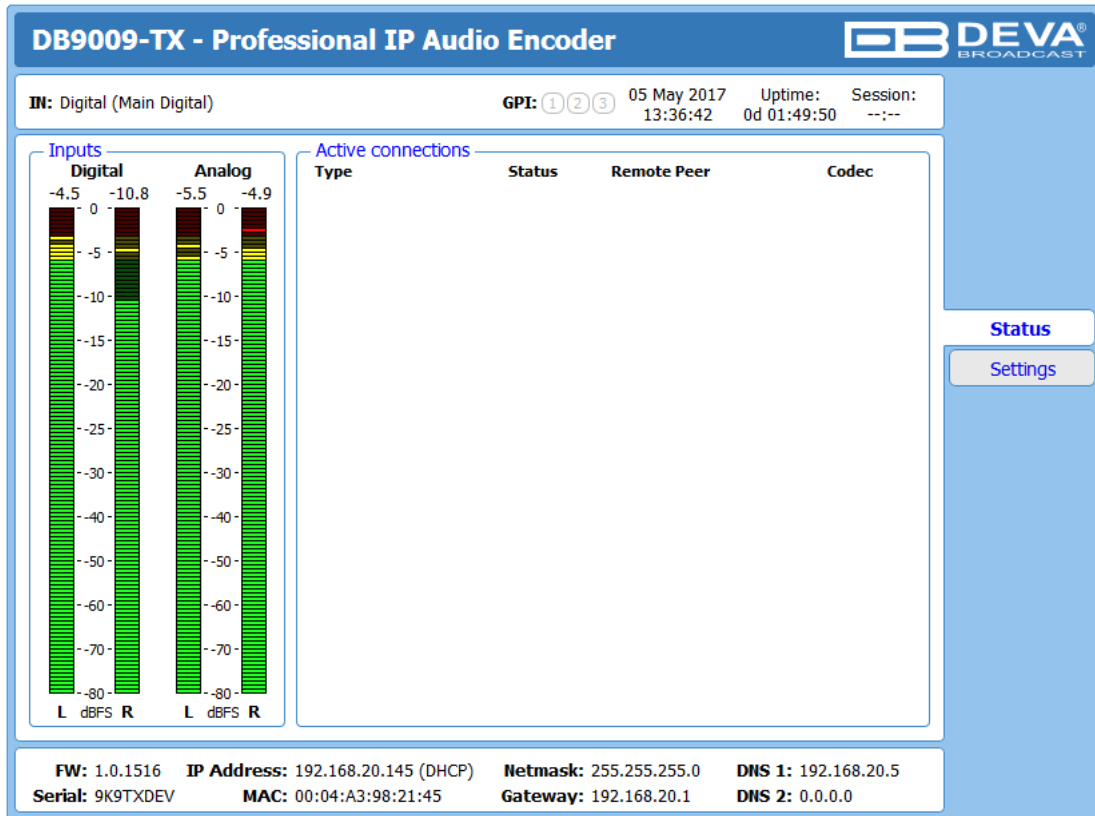

Upon opening the WEB interface, the main Status window will appear. The page contains information on the device's current status - the LED bar-graph representation of the left and right Digital and Analog audio levels in dBFS, as well as the Active connections - Type, Status, Remote Peer and Codec.

At the top of the control window is placed a constant section, containing information about the input in use, GPI, Date/Time, Uptime and session timeout.

At the bottom of the control window is an information bar, gathering all the important connection parameters – firmware version in use, serial number, IP Address, and etc.

Upon change of the Web Interface screens, the main status window will resize automatically and become a constant part of each tab. Thus, allowing reading at a glance of all the mandatory parameters.

## SETTINGS

**DB9009-RX - Professional IP Audio Decoder**

IN: IP Audio 2 (DB91-TX Demo)      GPI: ① ② ③      13 Jun 2017      Uptime:      Session:  
12:13:09      0d 00:00:27      --:--

**Backup 2**      **Main**      **Not Used**      **Not Used**      **Backup 1**      **Auto**

**IP Audio 1**      **IP Audio 2**      **IP Audio 3**      **RTP**      **MP3 Player**      **Output**

-80.0 -80.0      -5.5 -5.8      -0 -      -0 -      -80.0 -80.0      -5.4 -5.7

0 -      0 -      0 -      0 -      0 -      0 -  
-10 -      -10 -      -10 -      -10 -      -10 -      -10 -  
-20 -      -20 -      -20 -      -20 -      -20 -      -20 -  
-30 -      -30 -      -30 -      -30 -      -30 -      -30 -  
-50 -      -50 -      -50 -      -50 -      -50 -      -50 -  
-70 -      -70 -      -70 -      -70 -      -70 -      -70 -

**Welcome!**

Username:

Password:

[Status](#)

[Settings](#)

DB9009-TX provides you with a protected access to the device settings. In order to make the necessary adjustments to the device, please log in as an ADMINISTRATOR (username: *admin*, password: *pass*).

# INPUT

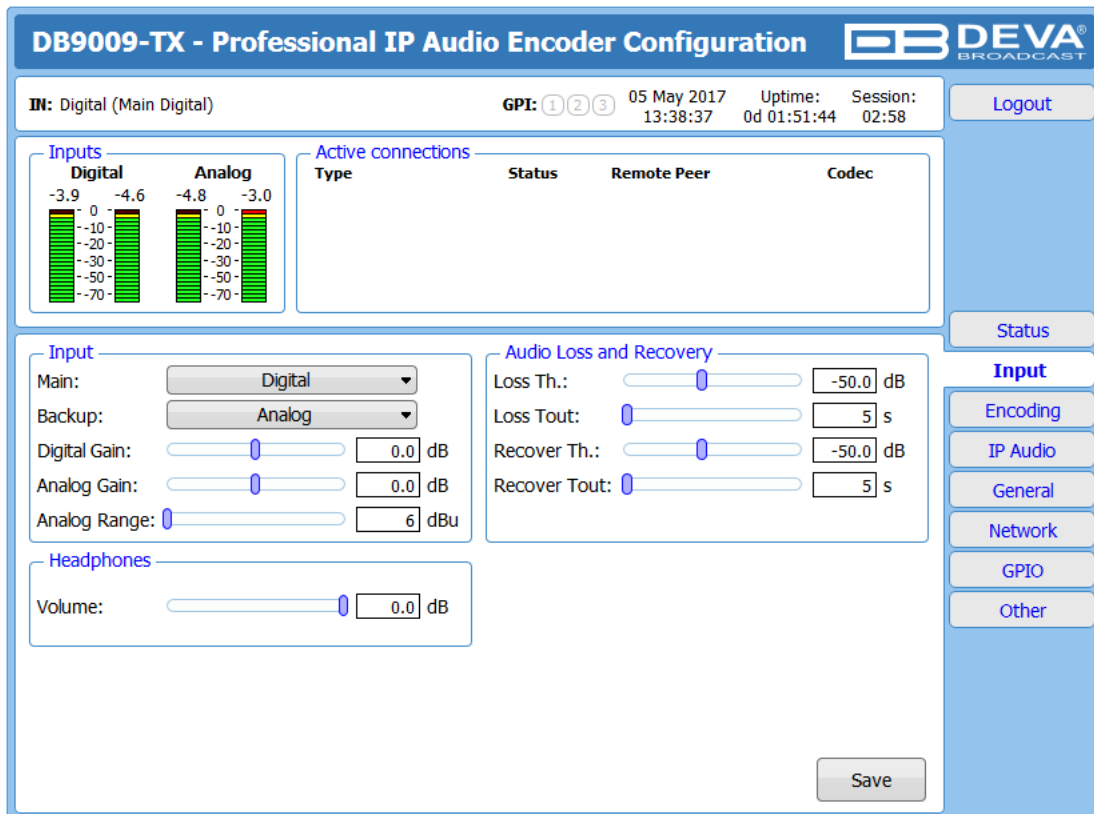

**DB9009-TX - Professional IP Audio Encoder Configuration**

IN: Digital (Main Digital)      GPI: ①②③      05 May 2017      Uptime:      Session:  
 13:38:37      0d 01:51:44      02:58      Logout

**Inputs**

Digital: -3.9, -4.6      Analog: -4.8, -3.0

**Active connections**

Type	Status	Remote Peer	Codec

**Input**

Main: Digital (dropdown)  
 Backup: Analog (dropdown)

Digital Gain: 0.0 dB  
 Analog Gain: 0.0 dB  
 Analog Range: 6 dBu

**Audio Loss and Recovery**

Loss Th.: -50.0 dB  
 Loss Tout: 5 s  
 Recover Th.: -50.0 dB  
 Recover Tout: 5 s

**Headphones**

Volume: 0.0 dB

Save

**Input** – select analog or digital input to be used as Main or Backup audio source. It is not mandatory Backup input to be specified. An option **Not used** is also available from the drop down menu. The Digital Gain, Analog Gain and Analog range are also user defined.

**Audio Loss and Recovery** - The conditions when backup source has to be used should also be specified (loss and recovery threshold and timeout).

**Headphones** - the interactive slider allows you to control the volume of the headphones from -30dB to 0dB.

**NOTE:** In order the applied settings to be used press the [Save] button, placed on the bottom right part of the screen.

If the Backup audio source is activated, the following message will appear on the main screen.

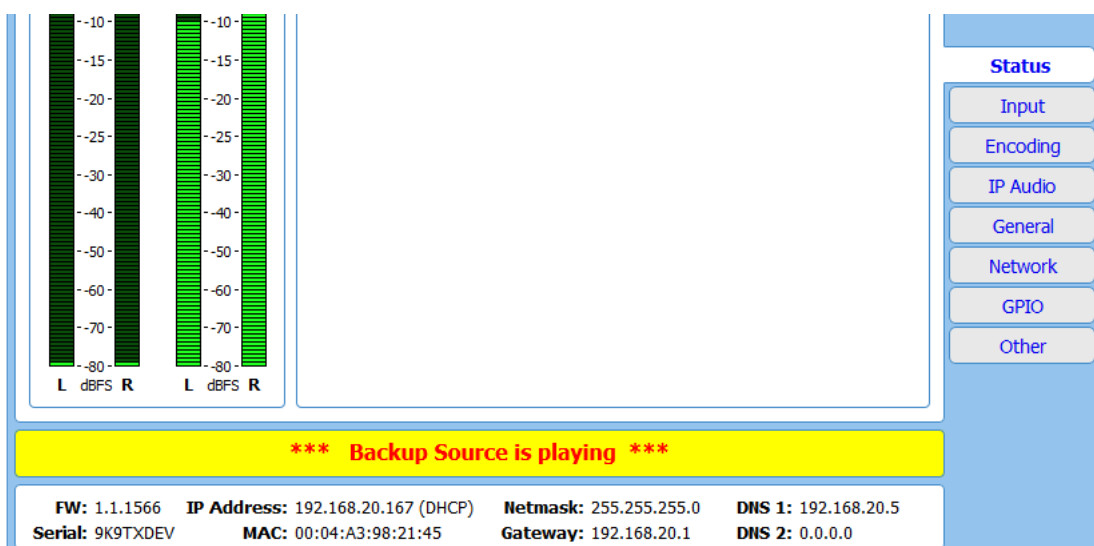

**\*\*\* Backup Source is playing \*\*\***

FW: 1.1.1566      IP Address: 192.168.20.167 (DHCP)      Netmask: 255.255.255.0      DNS 1: 192.168.20.5  
 Serial: 9K9TXDEV      MAC: 00:04:A3:98:21:45      Gateway: 192.168.20.1      DNS 2: 0.0.0.0

Navigation sidebar: Status, Input, Encoding, IP Audio, General, Network, GPIO, Other

## ENCODING

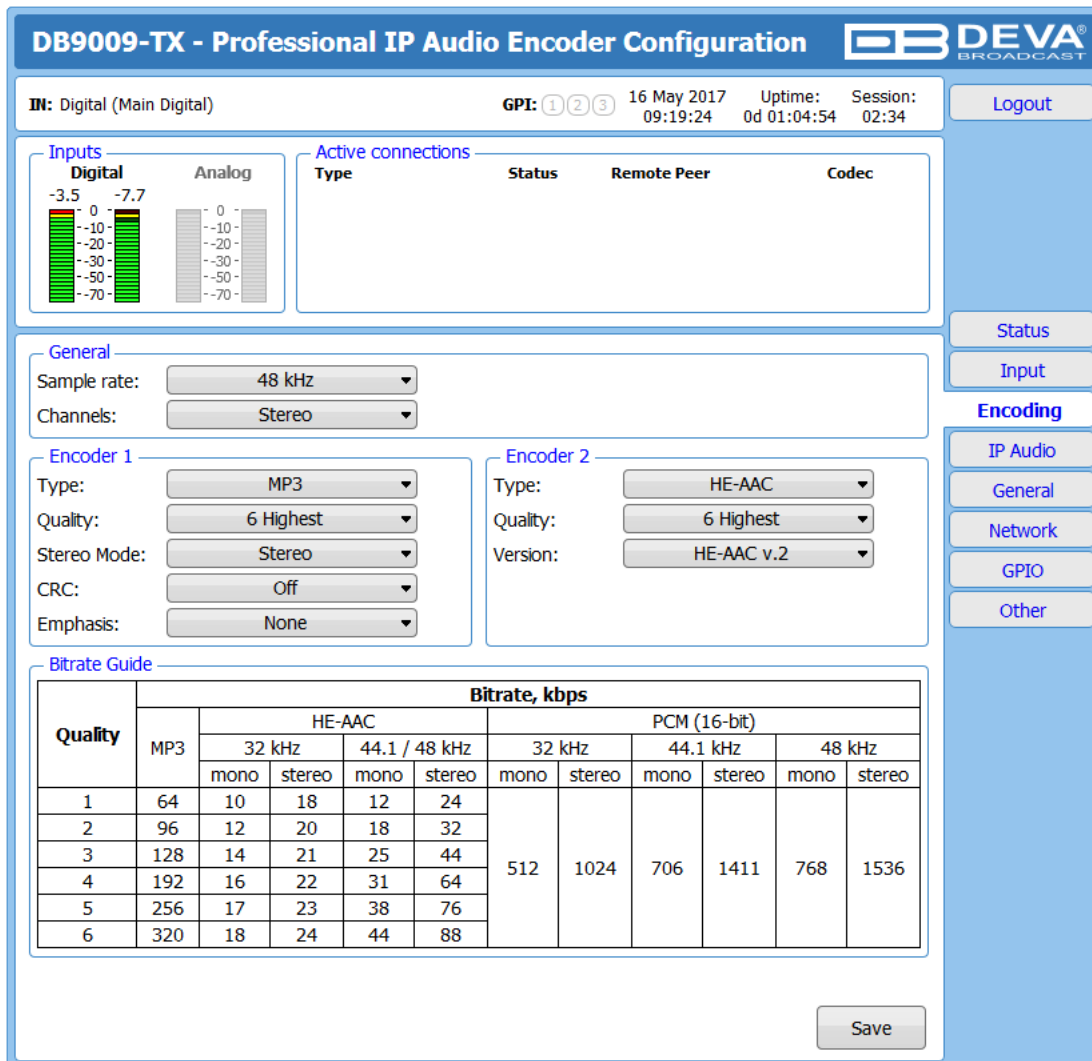

**DB9009-TX - Professional IP Audio Encoder Configuration**

IN: Digital (Main Digital)      GPI: ①②③      16 May 2017      Uptime:      Session:  
 09:19:24      0d 01:04:54      02:34      Logout

**Inputs**

Digital: -3.5, -7.7      Analog: 0, -10, -20, -30, -50, -70

**Active connections**

Type	Status	Remote Peer	Codec

**General**

Sample rate: 48 kHz  
 Channels: Stereo

**Encoder 1**

Type: MP3  
 Quality: 6 Highest  
 Stereo Mode: Stereo  
 CRC: Off  
 Emphasis: None

**Encoder 2**

Type: HE-AAC  
 Quality: 6 Highest  
 Version: HE-AAC v.2

**Bitrate Guide**

Quality	Bitrate, kbps										
	MP3	HE-AAC				PCM (16-bit)					
		32 kHz		44.1 / 48 kHz		32 kHz		44.1 kHz		48 kHz	
	mono	stereo	mono	stereo	mono	stereo	mono	stereo	mono	stereo	
1	64	10	18	12	24	512	1024	706	1411	768	1536
2	96	12	20	18	32						
3	128	14	21	25	44						
4	192	16	22	31	64						
5	256	17	23	38	76						
6	320	18	24	44	88						

Save

**General** - Specify Sample rate and Channels. These settings have influence on all codecs-PCM, Encoder 1 and Encoder 2.

**IMPORTANT NOTE:** As the only settings applicable to PCM are Sample rate and Channels, a specific section is not available. Quality does not apply to PCM stream. For PCM stream bitrate is calculated by the following equation: (sample rate)\*(Number of channels)\*16, [bps].

The settings applied to **Encoder 1** and **Encoder 2** are intended for MP3 and HE-AAC codecs. The applicable settings are explained in details below:

### Using MP3 codec

**Type** – select MP3.

**Quality** – Audio quality varies from 1 (Poor) to 6 (Excellent). Quality determines bitrate of the encoded stream. For MP3 encoded stream bitrate is independent of other parameters. For further information, refer to Bitrate Guide table. Please note all rates are in kbps.

**Stereo mode** – set the preferred mode from the drop-down menu. The following options are available: Stereo, Joint Stereo, Dual channel.

**CRC** – select whether MP3 stream should contain information on error detection.

**Emphasis** – select the emphasis to be applied. Supported values are 50µs, CCITT J.17.

### Using HE-AAC codec

**Type** – select HE-AAC.

**Quality** – As explained above, the audio quality varies from 1 (Poor) to 6 (Excellent). Quality determines bitrate of the encoded stream. For HE-AAC encoded stream bitrate depends on encoder version, number of channels and sample rate. For further information, refer to Bitrate Guide table. Please note all rates are in kbps.

**Version** - Select the preferred HE-AAC version from the drop-down menu.

**NOTE:** In order the applied settings to be used press the [Save] button, placed on the bottom right part of the screen.



## IP AUDIO

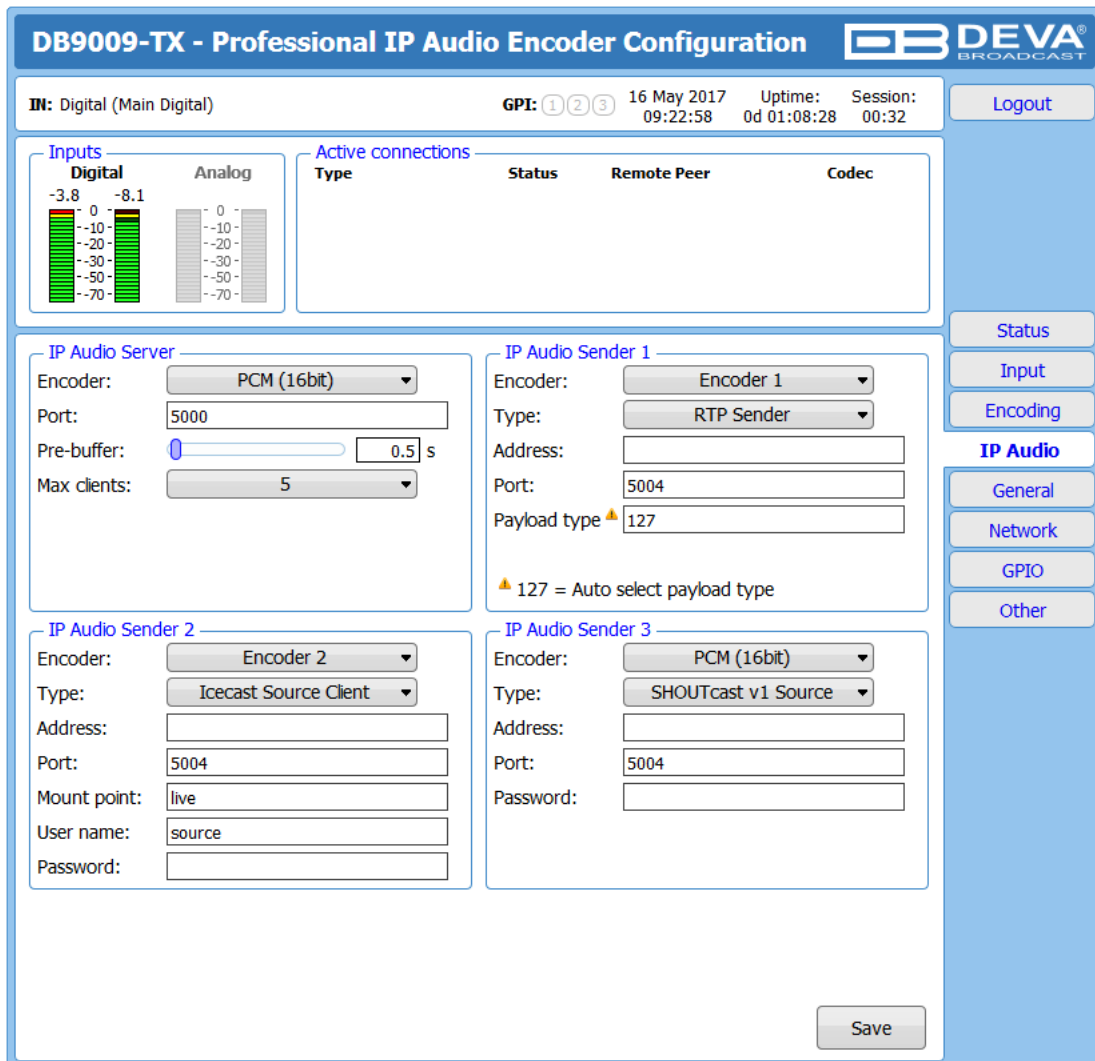

### IP Audio Server

- **Encoder** – select the encoder to be used - PCM (16bit), Encoder 1 or Encoder 2.
- **Port** – specify the TCP port of the stream server. The default value is 5000.
- **Pre-buffer** – initial amount of data sent to the client. Large value decreases startup delay caused by buffering on the client side. This also introduces the displayed amount of latency in the audio.
- **Max clients** – the maximum number of simultaneously connected clients. The maximum connections supported is 10. The default value is 5.

### IP Audio Sender 1/2/3

**RTP Settings** require Decoders' Server Address and Port to be entered in the respective fields:

- **Address** – URL or IP Address of the RTP Receiver.
- **Port** – UDP port of the RTP Receiver.

The RTP sender supports multicast streaming. In this mode Multicast Group address should be entered in the Address field.

### Icecast Settings

If DB9009-TX is used as an Icecast Source Mount point, Encoder IP Address and Port should be filled in. The username and password are used to secure the connection. Make sure to enter the same information on both sides of the connection.

- **Address** – URL or IP Address of the Icecast Server;

- **Port** – TCP port of the Icecast Server;
- **Mount point** – is a unique name on your server identifying a particular stream. A listener can only listen to a single mount point at a time. This means you can have a single Icecast server contain either multiple broadcasts with different content, or possibly the same broadcast but with streams of different bitrates or qualities. In this case each broadcast or stream is a separate mount point.
- **Username** – Username for Authentication with Icecast Server;
- **Password** – Password for Authentication with Icecast Server;

**NOTE:** The selected encoder must match the settings of the decoders on the other side of the connection.

#### **Shoutcast Settings**

If DB9009-TX is used as SHOUTcast v1 Source, Encoder IP Address and Port should be filled in. The password is used to secure the connection. Make sure to enter the same information on both sides of the connection.

**NOTE:** In order the applied settings to be used press the [Save] button, placed on the bottom right part of the screen.

## GENERAL

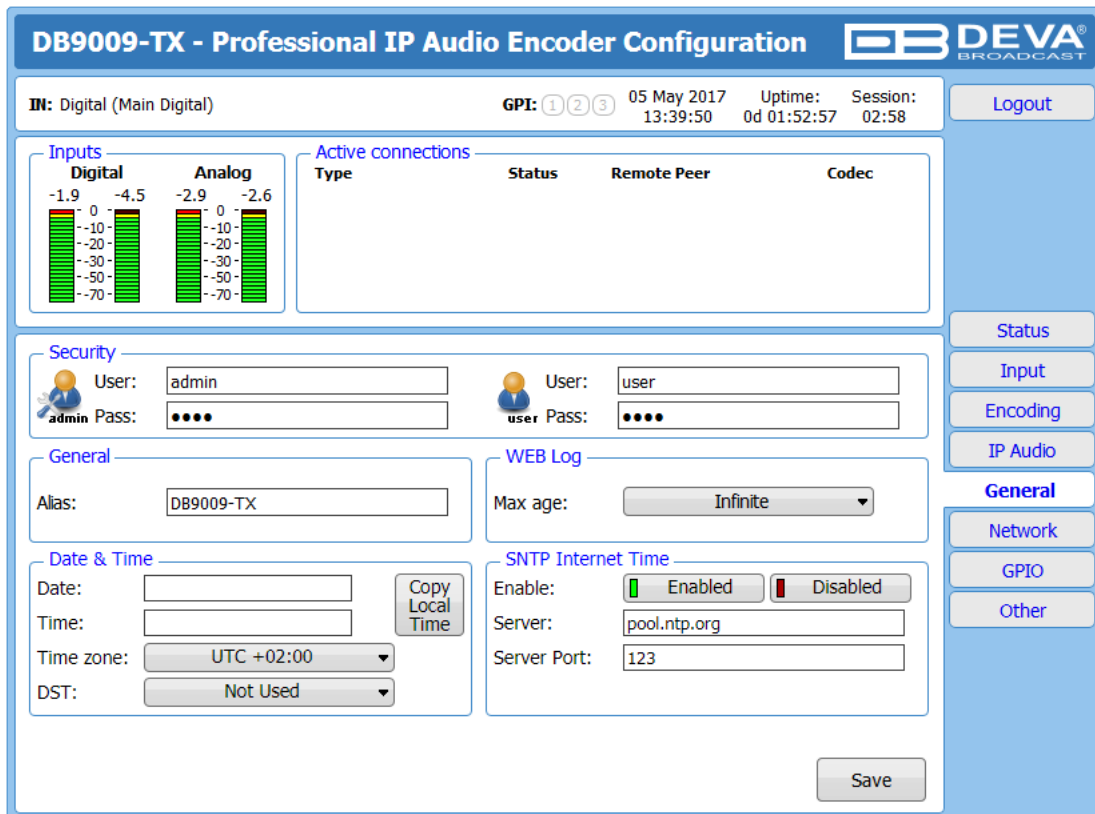

**DB9009-TX - Professional IP Audio Encoder Configuration**

IN: Digital (Main Digital)      GPI: ①②③      05 May 2017      Uptime:      Session:  
 13:39:50      0d 01:52:57      02:58      Logout

**Inputs**

Digital		Analog	
-1.9	-4.5	-2.9	-2.6
0	0	0	0
-10	-10	-10	-10
-20	-20	-20	-20
-30	-30	-30	-30
-50	-50	-50	-50
-70	-70	-70	-70

**Active connections**

Type	Status	Remote Peer	Codec

**Security**

admin User: admin      user User: user  
 admin Pass: ●●●●      user Pass: ●●●●

**General**

Alias: DB9009-TX

**WEB Log**

Max age: Infinite

**Date & Time**

Date:      Copy Local Time  
 Time:      Time zone: UTC +02:00  
 DST: Not Used

**SNTP Internet Time**

Enable:  Enabled       Disabled  
 Server: pool.ntp.org  
 Server Port: 123

Save

DB9009-TX provides you with protected access to the device settings. You can choose between two types of log in.

- As an ADMINISTRATOR – It will give you full control over the device’s settings;
- As a USER – that will allow you to just monitor the device, while all the settings remain locked.

In order for the security of DB9009-TX to be enhanced, new username and password could be set from the Security section.

By choice, you can change the name of the device (General section). Later on, it will be used as a title name on all WEB pages. Customizing the name will make the device more recognizable.

**Date & Time** – used for manually determining the current Date and Time. [Copy Local Time] button will set the Date & Time to correspond to that of your computer.

**SNTP Internet Time** – Synchronizes automatically DB9009-TX’s clock time to a millisecond with the Internet time server. Enable this function in order to use it (Specifying the server closest to your location will improve the accuracy).

**WEB Log** – the maximum storage time of the log files is chosen from here. Log files older than the specified will be permanently deleted.

**NOTE:** In order the applied settings to be used press the [Save] button, placed on the bottom right part of the screen.

## NETWORK

**DB9009-TX - Professional IP Audio Encoder Configuration**

III: Digital (Main Digital)
GPI: ①②③
05 May 2017
Uptime: 13:40:13
Session: 0d 01:53:20
02:58
Logout

**Inputs**

Digital		Analog	
-4.0	-7.6	-4.9	-4.7
0	0	0	0
-10	-10	-10	-10
-20	-20	-20	-20
-30	-30	-30	-30
-50	-50	-50	-50
-70	-70	-70	-70

**Active connections**

Type	Status	Remote Peer	Codec

**Network**

Enable:  Enabled

DHCP:  Enabled  Disabled

IP Address:

Netmask:

Gateway:

Primary DNS:

Sec. DNS:

**HTTP Server**

Enable:  Enabled

Server Port:

Session time:  min

**FTP Server**

Enable:  Enabled  Disabled

Cmd Port:

Data Port:

**E-mail**

Enable:  SMTP  DEVA  Disabled

E-mail 1:

E-mail 2:

E-mail account:

Username:

Password:

Host name:

Connection:

Server:

Server Port:

**SNMP Agent**

Agent:  Enabled  Disabled

Agent Port:

Agent ses. time:  min

Agent ID:

Read Community:

Write Community:

Manager IP:

Manager Port:

SNMP MIB File:

▲ - These settings require reboot.

### Network

The network addresses could be set manually (static IP) or automatically via a DHCP Server. To set static IP, MASK, GATEWAY and DNS addresses, the DHCP should be disabled. In order for the built-in DHCP client to be activated, the function should be enabled. When the DHCP client is activated, all assigned values will be shown in the relevant fields on the “Status Screen”. If due to any reason, the DHCP procedure cannot be completed, DB9009-TX will use Auto IP and will generate an IP Address.

### E-mail

Enter the desired alarm recipients in e-mail 1 and/or e-mail 2 fields. Fill in your e-mail account settings: Sender, Username and Password, Server, Server port and connection type. It is mandatory the type of connection with the server to be specified from Connection - Regular, Encrypted. The Server port will be changed accordingly. Please note that the most commonly used port will be entered in the field. If the port that is to be used is different, change it manually to the correct value.

If you experience difficulties in the set-up, or would like to use DEVA account for sending of alarm email notifications, press the [DEVA] button option, and complete the recipient emails (E-mail 1 and E-mail 2) only. The other fields must be left blank, otherwise the email notification option will not be working. Even though using the DEVA account eases the set-up process, we recommend user account to be used for sending of email notifications, and the DEVA account for test purposes. When using DEVA account, please note that the stable 24/7 connection depends on

the mail service provider and cannot be guaranteed.

We recommend you to use the [Test] button and generate a test e-mail, which upon success will be delivered to the specified E-mail 1 and/or E-mail 2.

Example of Test E-mail Message:

DB9009-TX Test Message.

Please do not reply to this e-mail.

### HTTP Server

Enable/Disable the HTTP Server. Specify the Server Port and Session Timeout.

### FTP Server

Enable/Disable the FTP Server. Specify the Command and Data Ports to be used.

For information on how the connection between the DB9009-TX and an FTP Client should be configured, please [refer to “Download files via FTP” on page 51](#).

### SNMP Agent

Specify Agent ID, Agent Port, Read/Write Communities, Manager IP, Manager Port and Agent Session Time.

**Agent** – enables/disables SNMP Agent.

**Agent ID** – is used for identification of the device among others, when an SNMP notification is being sent.

Once all needed settings are applied, use the Test button to generate a test notification, which upon success will be received by the SNMP Manager.

Press the [Download] button to download the latest available DB9009-TX SNMP MIB file.

**NOTE:** The MIB file may vary from one firmware revision to another. Downloading this file from the device, guarantees that you have the proper MIB file.

## GPIO

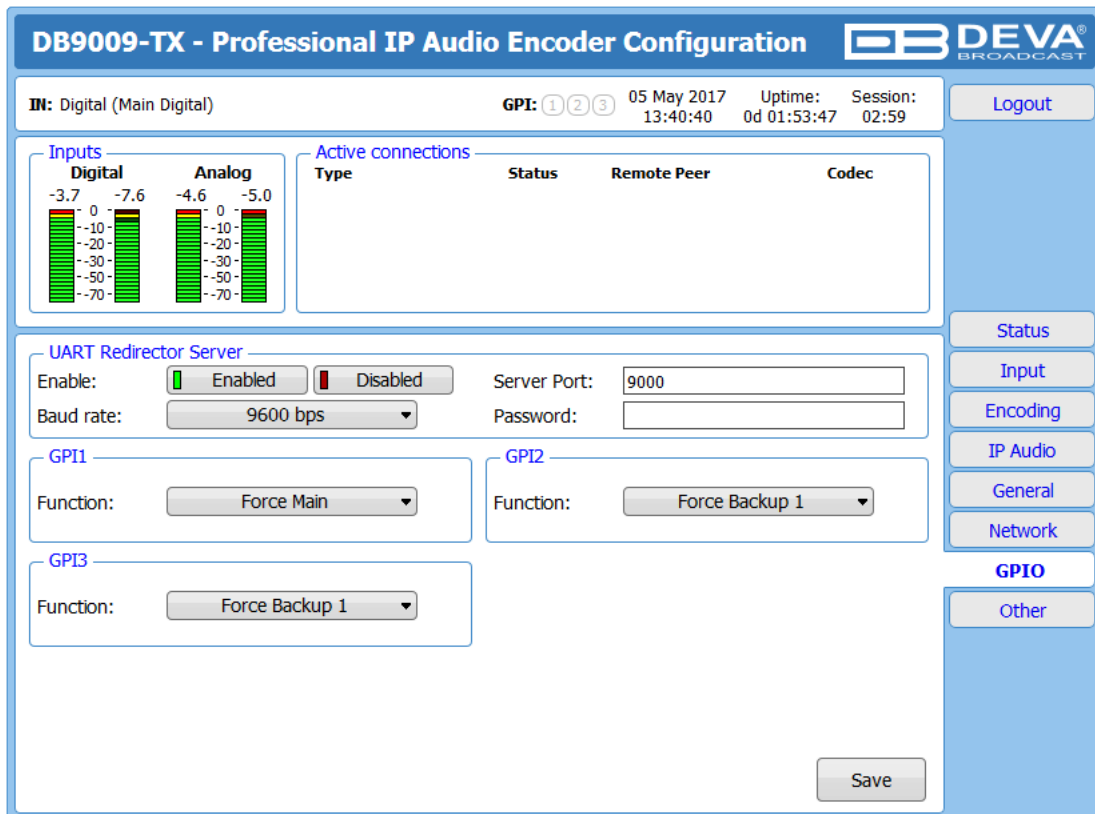

The screenshot shows the 'GPIO' configuration page for the DB9009-TX Professional IP Audio Encoder. The interface includes a top navigation bar with the DEVA logo and a sidebar with menu items: Status, Input, Encoding, IP Audio, General, Network, GPIO (selected), and Other. The main content area is titled 'DB9009-TX - Professional IP Audio Encoder Configuration' and displays the following settings:

- Inputs:** Digital level: -3.7, -7.6; Analog level: -4.6, -5.0. A table for 'Active connections' is present but empty.
- UART Redirector Server:** Enabled (checkbox), Baud rate: 9600 bps, Server Port: 9000, Password: (empty).
- GPI1:** Function: Force Main
- GPI2:** Function: Force Backup 1
- GPI3:** Function: Force Backup 1

A 'Save' button is located at the bottom right of the configuration area.

The general purpose outputs/inputs settings are applied through this page.

**UART Redirector Server** – DB9009-TX also acts as Ethernet to RS-232 redirector. You can connect any RS-232 compatible equipment to DB9009-TX and communicate with it over the Internet. The option can be either [Enabled] or [Disabled].

**Baud rate** – Select baud rate of the RS-232 COM Port. The external equipment must be configured to the same baud rate.

**Port** – a field where TCP port of the Ethernet to RS-232 redirector is to be entered. This is the TCP port used to communicate with any external device connected to the RS-232 COM Port.

**Password** – Password for the RS-232 server. These are the first symbols that must be sent to authenticate to the Ethernet to RS-232 redirector, otherwise the connection is dropped. If left blank NO security is used. Default value is blank (empty).

**GPI1 to GPI3** – Each can be assigned to force either the Main or Backup audio sources.

## OTHER

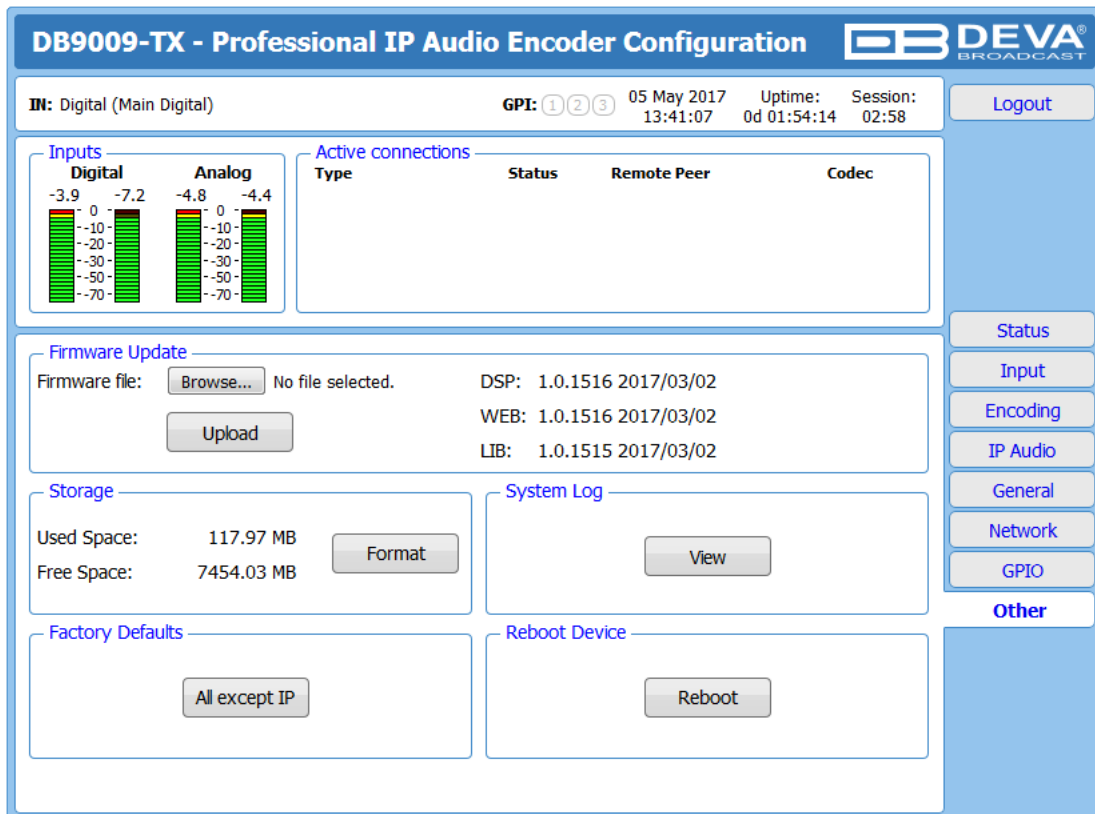

### Firmware Update

To update the device firmware, press [Browse] and select the new firmware file. After having pressed the [Upload] button, a dialog window will appear. Confirm the firmware update and wait for the process to complete.

**IMPORTANT NOTE:** If the firmware is downloaded from [www.devabroadcast.com](http://www.devabroadcast.com), the file must be unzipped prior to the upgrade.

### Storage

Information about the device storage space is found in this section. The internal storage could be deleted by pressing the [Format] button.

### System Log

By pressing the [View] button, a window with the following options will appear:



Pressing the [Clear] button will delete all recorded in the system log information.

Pressing the [Reload] button will update the displayed information.

### Factory Defaults

[All except IP] – all settings except for the Network settings (IP addresses) will be deleted.

To restore DB9009-TX to its factory defaults press the button. A new window will appear - confirm that you want to restore the factory defaults and wait for the process to be completed. On completion of the process, the settings should have the proper default values.

### Reboot Device

To reboot the DB9009-TX, press the [Reboot] button. A dialog warning window will appear. Confirm that you want to reboot the device and wait for the process to be completed.

## APPENDIX A

### RDS: EUROPE VS AMERICA

---

The European Broadcasting Union (EBU) and its member countries originated the concept of “Radio Data” transmission. The European RDS specification, CENELEC Standard EN50067, was first published in 1984. It was revised in 1986, 1990, 1991 and 1992.

European RDS has grown in use following initial adoption of the Standard. RDS is nearly universal throughout Europe; it is almost impossible to find a European FM broadcasting station that does not carry a radio data subcarrier.

The popularity of RDS in Europe is very much in contrast with initial reluctance on the part of US broadcasters to embrace this technology. This can be ascribed to material differences in broadcasting practices.

Almost without exception, FM broadcasting in the United States is ‘detached’ and independent - each station originates its own programming. America’s National Public Radio might be considered as an exception, though for most of the broadcast day even NPR stations originate, or at least schedule, their own programs.

Most of European broadcasting is similar to the concept of network radio that was common in the US prior to the 1950s. In Europe, a central program originator may have many transmitting facilities of modest power situated throughout the country, at several different frequencies to blanket a designated service area. The European disposition, toward lower-power transmitters can be found on the “local radio” level, as well.

The European concept of a service area equates to the US broadcaster’s market. The subtle difference between these designations further characterizes broadcasting practices and ethics. RDS benefits the European broadcaster through almost an altruistic endeavor to be of service to his listeners. The US broadcaster is marketing his programming and is primarily interested in how he can create additional revenue from RDS.

### THE RDS SYSTEM

---

RDS is a digital data channel, transmitted as a low-level subcarrier above the range of the composite stereo program signal in the FM baseband. The data transmission (baud) rate is comparatively low, yet it is quite robust because of data redundancy and effective error correction.

It is not within the scope of this Manual to cover the details of RDS subcarrier coding and modulation. For this, the reader is directed to the Specification appropriate to his location either the CENELEC EN50067 Specification for Europe or the United States NRSC Specification. Since the Manual will deal with specific implication of RDS implemented with the DB9009-TX, it is assumed that the user is familiar with the RDS concept.



## APPENDIX B.1

### PTY Code Description Used in RBDS Mode – North America

PTY	Short Name	Description
1	News	News reports, either local or network in origin.
2	Information	Programming that is intended to impart advice.
3	Sports	Sports reporting, commentary, and/or live event coverage, either local or network in origin.
4	Talk	Call-in and/or interview talk shows either local or national in origin.
5	Rock	Album cuts.
6	Classic Rock	Rock oriented oldies, often mixed with hit oldies, from a decade or more ago.
7	Adult Hits	An up-tempo contemporary hits format with no hard rock and no rap.
8	Soft Rock	Album cuts with a generally soft tempo.
9	Top 40	Current hits, often encompassing a variety of rock styles.
10	Country	Country music, including contemporary and traditional styles.
11	Oldies	Popular music, usually rock, with 80% or greater non-current music.
12	Soft	A cross between adult hits and classical, primarily non-current softrock originals.
13	Nostalgia	Big-band music.
14	Jazz	Mostly instrumental, includes both traditional jazz and more modern “smooth jazz.”
15	Classical	Mostly instrumentals, usually orchestral or symphonic music.
16	Rhythm and Blues	A wide range of musical styles, often called “urban contemporary.”
17	Soft R and B	Rhythm and blues with a generally soft tempo.
18	Foreign Language	Any programming format in a language other than English.
19	Religious Music	Music programming with religious lyrics.
20	Religious Talk	Call-in shows, interview programs, etc. with a religious theme.
21	Personality	A radio show where the on-air personality is the main attraction.
22	Public	Programming that is supported by listeners and/or corporate sponsors instead of advertising.
23	College	Programming produced by a college or university radio station.
24	Spanish Talk	Call-in shows, interview programs, etc. in the Spanish language
25	Spanish Music	Music programming in the Spanish language
26	Hip-Hop	Popular music incorporating elements of rap, rhythm-and-blues, funk, and soul
27-28	Unassigned	
29	Weather	Weather forecasts or bulletins that are non-emergency in nature.
30	Emergency Test	Broadcast when testing emergency broadcast equipment or receivers. Not intended for searching or dynamic switching for consumer receivers. Receivers may, if desired, display “TEST” or “Emergency Test”.
31	Emergency	Emergency announcement made under exceptional circumstances to give warning of events causing danger of a general nature. Not to be used for searching - only used in a receiver for dynamic switching.

**NOTE:** These definitions can differ slightly between various language versions.

## APPENDIX B.2

### PTY Code Description Used in RDS Mode – Europe, Asia

PTY	Short Name	Description
1	News	Short accounts of facts, events and publicly expressed views, reportage and actuality.
2	Current affairs	Topical program expanding or enlarging upon the news, generally in different presentation style or concept, including debate, or analysis.
3	Information	Program the purpose of which is to impart advice in the widest sense.
4	Sport	Program concerned with any aspect of sport.
5	Education	Program intended primarily to educate, of which the formal element is fundamental.
6	Drama	All radio plays and serials.
7	Culture	Programs concerned with any aspect of national or regional culture.
8	Science	Programs about the natural sciences and technology.
9	Varied	Used for mainly speech-based programs usually of light-entertainment nature, not covered by other categories. Examples include: quizzes, games, personality interviews.
10	Pop	Commercial music, which would generally be considered to be of current popular appeal, often featuring in current or recent record sales charts.
11	Rock	Contemporary modern music, usually written and performed by young musicians.
12	Easy Listening	Current contemporary music considered to be “easy-listening”, as opposed to Pop, Rock or Classical, or one of the specialized music styles, Jazz, Folk or Country. Music in this category is often but not always, vocal, and usually of short duration.
13	Light classics	Classical Musical for general, rather than specialist appreciation. Examples of music in this category are instrumental music, and vocal or choral works.
14	Serious classics	Performances of major orchestral works, symphonies, chamber music etc., and including Grand Opera.
15	Other music	Musical styles not fitting into any of the other categories. Particularly used for specialist music of which Rhythm & Blues and Reggae are examples.
16	Weather	Weather reports and forecasts and Meteorological information.
17	Finance	Stock Market reports, commerce, trading etc.
18	Children’s programs	For programs targeted at a young audience, primarily for entertainment and interest, rather than where the objective is to educate.
19	Social Affairs	Programs about people and things that influence them individually or in groups. Includes: sociology, history, geography, psychology and society.
20	Religion	Any aspect of beliefs and faiths, involving a God or Gods, the nature of existence and ethics.
21	Phone In	Involving members of the public expressing their views either by phone or at a public forum.
22	Travel	Features and programs concerned with travel to near and far destinations, package tours and travel ideas and opportunities. Not for use for Announcements about problems, delays, or roadworks affecting immediate travel where TP/TA should be used.
23	Leisure	Programs concerned with recreational activities in which the listener might participate. Examples include, Gardening, Fishing, Antique collecting, Cooking, Food & Wine etc.
24	Jazz Music	Polyphonic, syncopated music characterized by improvisation.
25	Country Music	Songs which originate from, or continue the musical tradition of the American Southern States. Characterized by a straightforward melody and narrative story line.
26	National Music	Current Popular Music of the Nation or Region in that country’s language, as opposed to International ‘Pop’ which is usually US or UK inspired and in English.
27	Oldies Music	Music from the so-called “golden age” of popular music.
28	Folk Music	Music which has its roots in the musical culture of a particular nation, usually played on acoustic instruments. The narrative or story may be based on historical events or people.
29	Documentary	Program concerned with factual matters, presented in an investigative style.
30	Alarm Test	Broadcast when testing emergency broadcast equipment or receivers. Not intended for searching or dynamic switching for consumer receivers.. Receivers may, if desired, display “TEST” or “Alarm Test”.
31	Alarm	Emergency announcement made under exceptional circumstances to give warning of events causing danger of a general nature. Not to be used for searching - only used in a receiver for dynamic switching.

## APPENDIX C

### HOW SHOULD I CONFIGURE THE CONNECTION BETWEEN MY DEVA DEVICE AND AN FTP CLIENT?

---

In order for a connection to be established the following setting should be applied:

#### 1. FTP Server Settings

The built-in FTP Server has four important parameters that should be configured: Command Port, Data Port, User name and Password. These parameters are to be used in the FTP client's connection configuration. Further information on how to change the FTP Server's settings and their respective default values can be found in the device's User manual.

**WE RECOMMEND** the usage of FileZilla (<https://filezilla-project.org>). This is a widespread open source software distributed free of charge, hence available for downloading from the Internet.

**NOTE:** The FTP Server can manage only one connection at a time. The FTP Server works in Passive mode. Hence, the FTP Client should also be set in passive mode.

#### 2. IP Router and Port Translation Settings

If the connection to the device is made through a Network address translation (NAT) router or firewall, the port forwarding feature of the router should be configured. The port forwarding is usually set in the firewall section of the router's menu. As each router has different port forwarding procedure, we recommend you to refer to its complete manual. To allow proper data flow through the router, the FTP Command and FTP Data ports should be open.

**NOTE:** The FTP port numbers to be used in the port forwarding feature configuration can be found in the device.

### 3. Example of FTP Client (FileZilla) Settings

In some cases, FileZilla's "Quick connect" feature is not able to connect with the DEVA unit. That is why we recommend the device to be assigned in the program manually.

Enter the FTP Client and go to: **File > Site manager > New Site**. A dialog box requiring obligatory information about the device will appear. Fill in the needed information and press "OK".

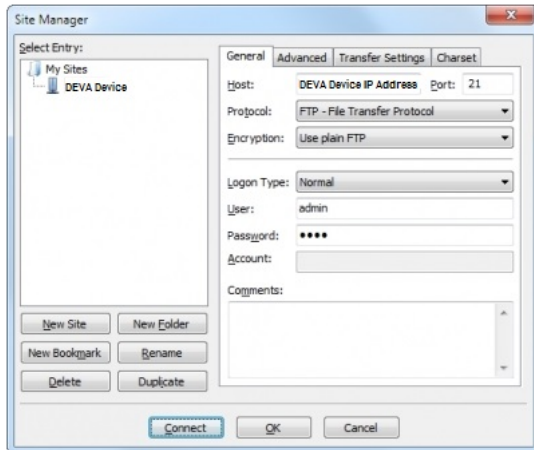

Select "Transfer Settings" sub-menu and apply the settings as shown below:

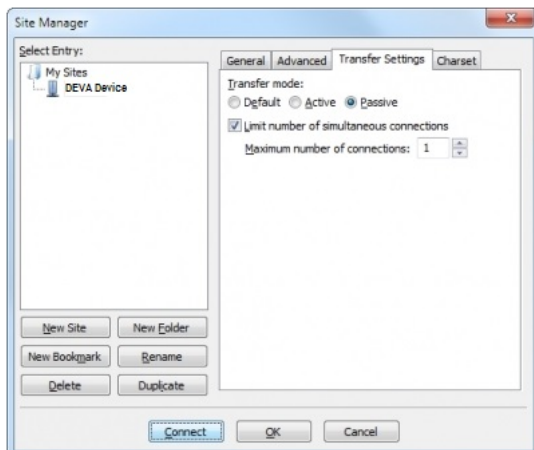

## WARRANTY TERMS AND CONDITIONS

**I. TERMS OF SALE:** DEVA Broadcast Ltd. products are sold with an understanding of “full satisfaction”; that is, full credit or refund will be issued for products sold as new if returned to the point of purchase within 30 days following their receipt, provided that they are returned complete and in an “as received” condition.

**II. CONDITIONS OF WARRANTY:** The following terms apply unless amended in writing by DEVA Broadcast Ltd.

**A.** The Warranty Registration Card supplied with this product must be completed and returned to DEVA Broadcast Ltd. within 10 days of delivery.

**B.** This Warranty applies only to products sold “as new.” It is extended only to the original end-user and may not be transferred or assigned without prior written approval by DEVA Broadcast Ltd.

**C.** This Warranty does not apply to damage caused by improper mains settings and/or power supply.

**D.** This Warranty does not apply to damage caused by misuse, abuse, accident or neglect. This Warranty is voided by unauthorized attempts at repair or modification, or if the serial identification label has been removed or altered.

**III. TERMS OF WARRANTY:** DEVA Broadcast Ltd. products are warranted to be free from defects in materials and workmanship.

**A.** Any discrepancies noted within TWO YEARS of the date of delivery will be repaired free of charge, or the equipment will be replaced with a new or remanufactured product at DEVA Broadcast Ltd. option.

**B.** Parts and labor for factory repair required after the two-year Warranty period will be billed at prevailing prices and rates.

### **IV. RETURNING GOODS FOR FACTORY REPAIR:**

**A.** Equipment will not be accepted for Warranty or other repair without a Return Material Authorization (RMA) number issued by DEVA Broadcast Ltd. prior to its return. An RMA number may be obtained by calling the factory. The number should be prominently marked on the outside of the shipping carton.

**B.** Equipment must be shipped prepaid to DEVA Broadcast Ltd. Shipping charges will be reimbursed for valid Warranty claims. Damage sustained as a result of improper packing for return to the factory is not covered under terms of the Warranty and may occasion additional charges.

## PRODUCT REGISTRATION CARD

- All fields are required, or warranty registration is invalid and void

Your Company Name \_\_\_\_\_

Contact \_\_\_\_\_

Address Line 1 \_\_\_\_\_

Address Line 2 \_\_\_\_\_

City \_\_\_\_\_

State/Province \_\_\_\_\_ ZIP/Postal Code \_\_\_\_\_

Country \_\_\_\_\_

E-mail \_\_\_\_\_ Phone \_\_\_\_\_ Fax \_\_\_\_\_

Which DEVA Broadcast Ltd. product did you purchase? \_\_\_\_\_

\_\_\_\_\_  
\_\_\_\_\_

Product Serial # \_\_\_\_\_

Purchase date \_\_\_\_ / \_\_\_\_ / \_\_\_\_

Installation date \_\_\_\_ / \_\_\_\_ / \_\_\_\_

\_\_\_\_\_  
Your signature\*

\*Signing this warranty registration form you are stating that all the information provided to DEVA Broadcast Ltd. are truth and correct. DEVA Broadcast Ltd. declines any responsibility for the provided information that could result in an immediate loss of warranty for the above specified product(s).

**Privacy statement: DEVA Broadcast Ltd. will not share the personal information you provide on this card with any other parties.**